

Black Bruin

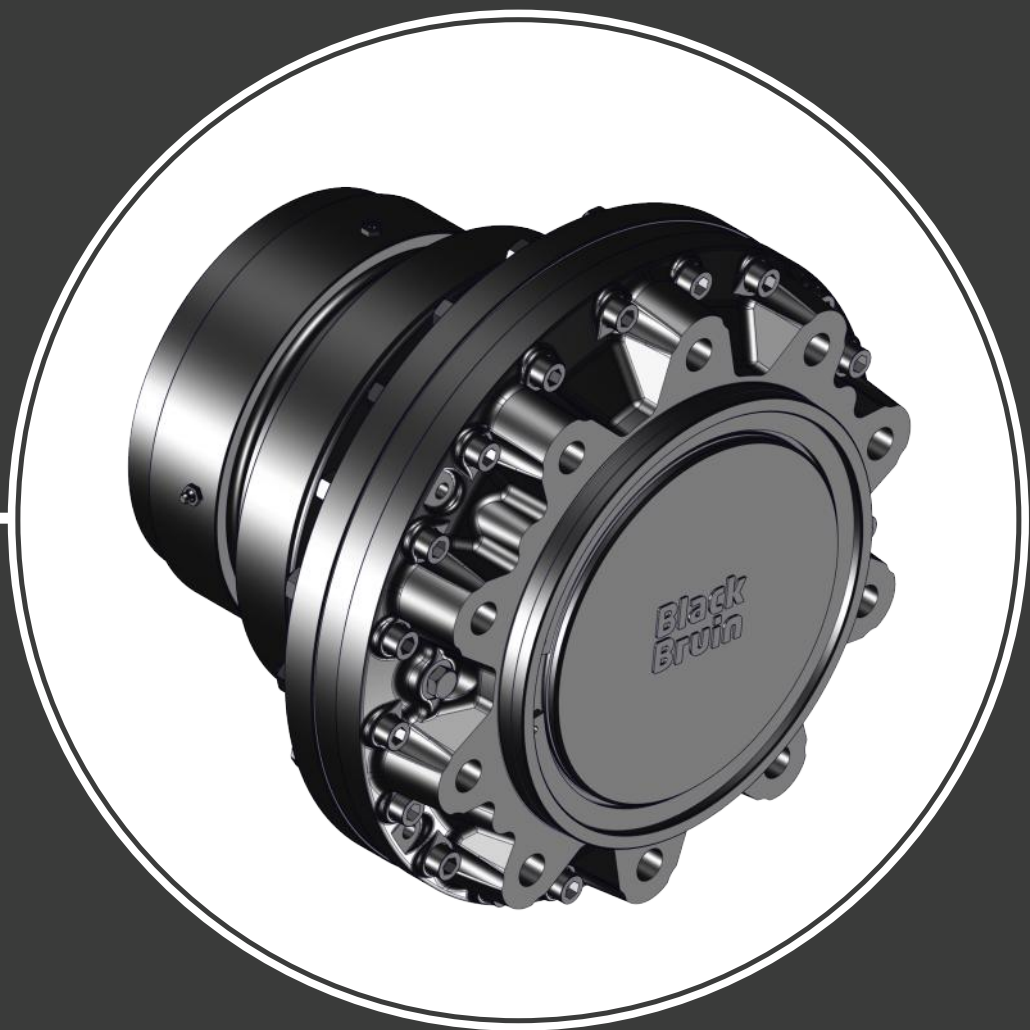

General Instructions

Contents

1	General Instructions.....	3
1.1	About the manual.....	3
1.2	Warranty.....	3
1.3	Product identification.....	3
1.4	Publication date.....	3
1.5	Declaration of incorporation.....	4
1.6	Safety Instructions.....	4
1.6.1	Warning symbols.....	5
1.7	Hydraulic fluid.....	5
1.7.1	Hydraulic fluid type.....	5
1.7.2	Hydraulic fluid properties.....	5
1.7.3	Hydraulic fluid cleanliness.....	6
1.8	Installation Instructions.....	6
1.8.1	Mounting the motor.....	6
1.8.2	Flushing the hydraulic system.....	7
1.8.3	Hydraulic connections.....	7
1.8.4	Air bleeding procedure.....	7
1.8.5	Commissioning procedure.....	8
1.9	Operating Instructions.....	8
1.9.1	Break-in period.....	8
1.9.2	Use.....	9
1.9.3	Seal protector.....	9
1.9.4	Operating temperature.....	9
1.9.5	Demounting the motor.....	10
1.10	Special Instructions.....	10
1.10.1	Storing the motor.....	10

1 General Instructions

1.1 About the manual

This manual contains the technical instructions for the Black Bruin hydraulic motors. Take these instructions into consideration when planning the use of the product.

All information given in this manual is current and valid according to the information available at the time of publication. The manufacturer reserves the rights to implement changes without prior notice.

Please visit www.blackbruin.com for the most recent version of this manual. The product datasheets and the 3D-models are available from the manufacturer by request.

1.2 Warranty

Check the package and the product for transport damage when receiving goods. The package is not meant for long term storage; protect the product appropriately.

Do not dismantle the product. The warranty is void if the product has been disassembled.

The manufacturer is not responsible for damages resulting from misinterpreted, non-compliance, incorrect, or improper use of the product that goes against the instructions given in this document.

1.3 Product identification

The product identification data can be found on the identification plate attached to the motor.

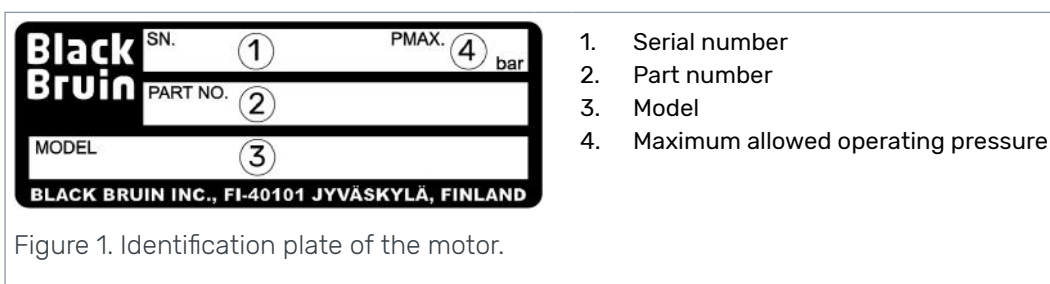

Figure 1. Identification plate of the motor.



Note:

The serial number is also stamped on the motor. All manufacturing data can be found with the serial number.

1.4 Publication date

16.05.2023 - This manual is published.

1.5 Declaration of incorporation

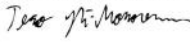
	DECLARATION OF INCORPORATION 1(1)
Black Bruin Inc.	2022-01-13
DECLARATION OF INCORPORATION (in accordance with EC Machinery Directive 2006/42/EC, Annex II B)	
Manufacturer	Black Bruin Inc.
Address	Valmetintie 9 FI-40420 Jyskä, FINLAND
Product description	Black Bruin hydraulic motor series: <ul style="list-style-type: none">▪ BBC▪ BB▪ B100▪ B200▪ C200▪ S
We hereby declare that the product(s) specified above is intended to be incorporated into machinery or to be assembled with other machinery to constitute machinery covered by EC Machinery Directive 2006/42/EC, as amended.	
And that the following harmonised standards have been applied: <ul style="list-style-type: none">▪ EN ISO 4413:2010 (Hydraulic fluid power - General rules and safety requirements for systems and their components)▪ EN ISO 12100:2010 (Safety of machinery – General principles for design – Risk assessment and risk reduction)	
And furthermore declares that the product(s) covered by this declaration must not be put into service until the final machinery into which it is to be incorporated has been declared in conformity with the provisions of EC Machinery Directive 2006/42/EC.	
The product(s) must be applied and installed in accordance with all the technical documents applicable to the product(s).	
This document supersedes all previous releases to this subject.	
Place and date	Jyväskylä, 2022-01-13 On behalf of Black Bruin Inc. 
Name	Tero Ylä-Mononen
Title	R&D Manager
<hr/>	
BLACK BRUIN INC. P.O. Box 633, FI-40101 JYVÄSKYLÄ, FINLAND +358 20 755 0755 info@blackbruin.com www.blackbruin.com	

1.6 Safety Instructions

The following instructions apply to all procedures associated with the motor. Read these instructions carefully and follow them closely.

- Use necessary personal protective equipment when working with the motor.

- Support the motor properly. Make sure the motor cannot fall over or turn around by accident.
- Use only appropriate equipment and attachments for lifting and transferring the motor.
- Do not use magnetic lifting devices.
- Always use the lifting equipment properly and check the load-bearing capacity.
- Prevent unintended use of the motor during installation and maintenance procedures by preventing pressurization of the hydraulic lines.
- The operating temperature of the motor may be over 60 °C (140 °F), which is hot enough to cause severe burns. Beware of hot hydraulic fluid when disconnecting the hydraulic connections.

1.6.1 Warning symbols

The following symbols are used in this manual:



Note:

Useful information.



Danger:

Danger of death or injury.



Attention:

May cause damage to the product.

1.7 Hydraulic fluid

1.7.1 Hydraulic fluid type

Black Bruin hydraulic motors are designed to work with hydraulic fluids based on mineral oil. Consider the following requirements when choosing hydraulic fluid:

- Hydraulic oils in accordance with ISO 6743-4 are recommended to be used.
- Motor oils in accordance with API-grades SF, SG, SH and SL may also be used.
- Fire resistant hydraulic fluids HFB and HFC or similar may be used under certain circumstances.

1.7.2 Hydraulic fluid properties

Requirements concerning the hydraulic fluid properties:

- The recommended fluid viscosity range for constant use is 25 - 50 cSt.
- The minimum permissible intermittent viscosity is 15 cSt.
- The maximum permissible viscosity during motor startup is 1000 cSt.
- The viscosity index must be at least 100.
- The water content of hydraulic oil should be less than 500 ppm (0,05 %).
- The hydraulic fluid must reach score 10 on a wear protection test FZG A/8,3/90 in accordance with ISO 14635-1 (DIN 51354)
- The effect of the additives improving the viscosity index can decrease during operation.



Note:

Temperature has a significant effect on the viscosity and the lubricating capability of the hydraulic fluid. Take into consideration the real operating temperature when defining the fluid viscosity.

The need for service and the overall service life may be improved by using hydraulic fluids with higher viscosity. In addition higher viscosity may improve the running smoothness.

1.7.3

Hydraulic fluid cleanliness

Hydraulic fluid must fulfill cleanliness level 18/16/13 in accordance with ISO 4406 (NAS 1638 grade 7).



Note:

The purity of the hydraulic fluid has a significant effect on the need for service and the overall service life of the motor.

1.8

Installation Instructions

1.8.1

Mounting the motor

The installation dimensions and tightening torques are given in the product datasheet.

Check the following things before installing the motor:

- The counter surfaces must be clean and even.
- Make sure that the strength class (grade) of the fastening screws is sufficient.
- Make sure that the fastening screws are of suitable size and length.
- The fastening screws should be cleaned and oiled lightly before installing them.
- Use threadlocker only if necessary, removing the old threadlocker may be difficult.
- Remove any old threadlocker before mounting the motor.



Note:

When replacing fastening screws with new ones, renew all of the screws.



Attention:

When using stud bolts, do not tighten the bolt. Tightening of the stud bolt is done with the nut.

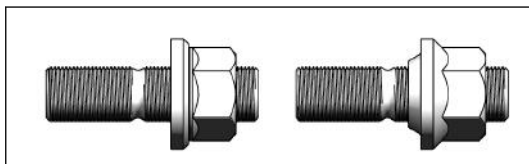

Figure 2. Stud bolt variants.



Attention:

The load carrying capacity of a rotating housing motor is applicable when the drain line (C) is orientated to the load direction.

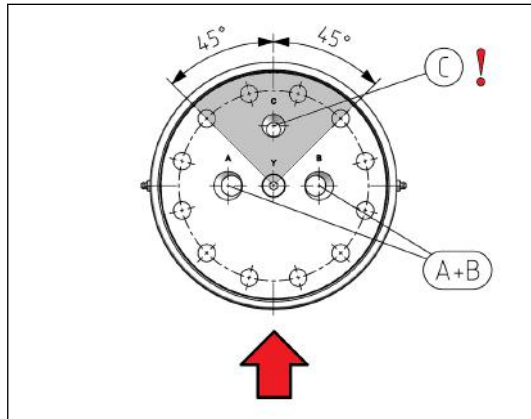

Figure 3. Motor orientation to the load direction.

1.8.2 Flushing the hydraulic system

Prior to connecting the motor as part of the hydraulic system, the hydraulic circuit of the motor must always be flushed by circulating hydraulic fluid through a filter installed in place of the motor.

The flushing is carried out by circulating hydraulic fluid through the entire system with a minimum pressure for at least an hour.

- After flushing, renew all filters.



Note:

Flushing the hydraulic system should also be performed after every system modification or repair.

1.8.3 Hydraulic connections



Warning:

Do not apply the working pressure to the case drain line port (C, C1 or C2). This can break the motor.

Before you make any hydraulic connections to the motor, examine the motor product datasheet for the correct hydraulic connections.

1.8.4 Air bleeding procedure

For the motor

Air bleeding procedure is carried out to fill the housing of the motor completely with hydraulic fluid. Air is removed from the housing with air bleeding screws as follows:

- Locate the topmost air bleeding screw.
- Make sure the drain line of the motor is connected.
- Feed hydraulic fluid into the motor with low pressure throughout the procedure.
- Unscrew the air bleeding screw by half a turn and let air escape from the housing.
- Close the screw when only hydraulic fluid is pouring through it.
- Tighten the screw to a torque of 39 ± 3 Nm.

For the holding brake

Before using the brake the air bleeding procedure must be taken care of. Air bleeding procedure is carried out to fill the housing of the brake completely with hydraulic

fluid. Brake housing is separate from the motor housing so the air bleeding procedure must be made separately for motor and brake. Air is removed from the brake housing with air bleeding screws as follows:

- Feed hydraulic fluid into the brake via port D throughout the air bleeding procedure.
- Locate the topmost air bleed screw of the housing.
- Unscrew the air bleeding screw by half a turn and let air escape from the housing.
- Close the screw when only hydraulic fluid is pouring through it.
- Tighten the screw to a torque of 39 ± 3 Nm.



Note:

The location of the air bleed screws can be found in the product datasheet.

If feed pressure is not available, fill the housing manually by pouring hydraulic fluid in the motor through the topmost opening of the housing.

1.8.5 Commissioning procedure

Ensure that the following things are in order before starting a new or replaced motor:

- The hydraulic circuit of the motor is flushed.
- Motor is installed appropriately.
- Air bleeding procedure is carried out.
- The reservoir of the hydraulic system is full.

During the initial stages of use, also take the following things into consideration:

- Do not run the motor immediately with full power. Increase the load and speed of rotation gradually.
- Observe the motor and the hydraulic system for external leaks or abnormal noises during the commissioning procedure.
- Start the motor break-in.



Note:

During all installation and service procedures, plug any open ports and hoses.

When filling the reservoir, add hydraulic fluid through a filter.



Attention:

Do not start the motor, if the air bleeding procedure has not been carried out.

Stressing an unused motor with full power may cause premature wear or failure of the motor.

1.9 Operating Instructions

1.9.1 Break-in period

The motor achieves its final properties during the first hours of use. Therefore all new and reconditioned motors should go through an initial break-in period.

Things to be considered during break-in period:

- The break-in period should last for at least first eight hours (8 h) of use.
- The power output should remain under 50 % of the maximum power capacity of the motor.

- The power output is limited by limiting the working pressure, the speed of rotation or both.
- The working pressure should be limited so, that pressure peaks which last over two seconds (2 s) remain under 75 % of the permissible values.



Note:

During the break-in period, the moving parts of the motor wear against each other so, that the wear of the parts sets to a stable state for the entire service life of the motor.

1.9.2

Use

Things to be considered during use of motors:

- Check the screw connections tightening torque and hydraulic connections regularly.
- Do not use pressure cleaning directly between the shaft and housing of the motor (the shaft seal area).
- Avoid situations in which the motors are completely submerged in water or mud.

1.9.3

Seal protector

The seal protector provides protection for the motor’s seal against outside impurities.

- In dirty environment lubricant is needed to add regularly.
- Lubricate the seal protector as part of the vehicle lubrication routine.
- Observe lubrication adequacy during use and increase or decrease lubrication as needed. In clean and dry environment there is no need to add lubrication.
- Add lubricant from both nipples during operation. Add lubricant when the motor is warm.

The lubricant pocket is filled with NLGI-1 lubricant (e.g. Microlube GL 261). Use only compatible lubricants. The lubricant is mineral oil-based grease which is precipitated with lithium-soap.

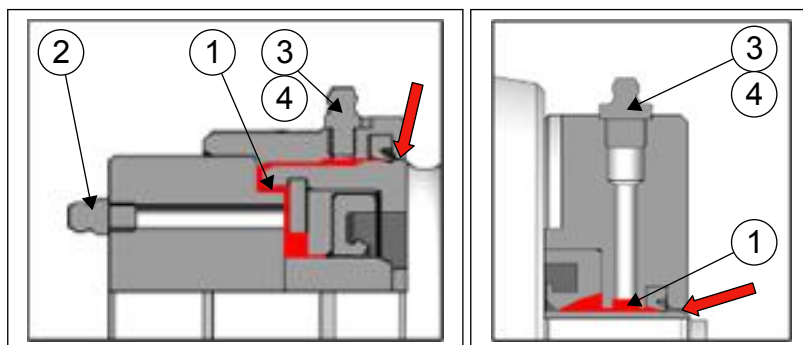

- Lubricant pocket (1)
- Grease nipple (2 or 3): position may vary depending on motor model (2 or 3)
- Check valve (4): depending on motor model the seal protector may have check valve. Possible drainage of lubricant.
- Possible drainage of lubricant (red arrow)

1.9.4

Operating temperature

The operating temperature means the internal temperature of the motor. Take into considerations the following requirements for the operating temperature:

- For improved service life, avoid over 70 °C (158 °F) operating temperature.
- The highest permissible intermittent operating temperature is 85 °C (185 °F).

General Instructions

- The lowest permissible operating temperature is -35 °C (-31 °F).
- The temperature difference between the motor and the hydraulic fluid should be under 60 °C (140 °F).

The operating temperature may be measured from the hydraulic fluid returning from the motor. Take into account the temperature of hydraulic fluid returning from the drain line and from the return line (A or B).

1.9.5 Demounting the motor

Take into consideration the following things when demounting the motor for service or replacement:

- Release the pressure in the hydraulic lines and let the motor cool down.
- Disconnect all the hydraulic lines from the motor and plug all openings and hoses.
- Demount the motor and lift it away from its position.
- Clean the outside of the motor thoroughly, but do not use any solvents.
- Protect the cleaned motor from corrosion.
- If possible, drain all the hydraulic fluid from the motor.



Note:

Dispose of hydraulic fluid should be done appropriately.

1.10 Special Instructions

1.10.1 Storing the motor

During short term storage of the motor, the following should be taken into consideration:

- Cover any pressure openings and open threaded holes with suitable caps.
- Protect the unpainted surfaces from dirt and moisture.
- Store the motor in a dry place with relatively stable temperature.
- The motor should not be stored in a same place as substances with aggressive corrosive nature (solvents, acids, alkalis and salts).
- The motor should not be exposed to strong magnetic fields.
- The motor should not be exposed to strong vibration.



Note:

For long-term storage (over 9 months) the following additional actions are recommended:

- Damages to surface paint must be repaired.
- Protect the unpainted surfaces with suitable anti-corrosion treatment.
- Fill the motor completely with hydraulic fluid.

If these instructions are followed, the motor may be stored for approximately two years. However, as storage conditions do have a significant effect, these times should only be considered as guide values.

