

# Black Bruin



**Product Manual  
X series**

# Contents

<b>1</b>	<b>General Instructions.....</b>	<b>4</b>
1.1	About the manual.....	4
1.2	Intended use.....	4
1.3	Warranty.....	4
1.4	Product identification.....	4
1.5	Publication date.....	4
1.6	Declaration of incorporation.....	5
<b>2</b>	<b>Safety Instructions.....</b>	<b>6</b>
2.1	Warning symbols.....	6
<b>3</b>	<b>Motor Description.....</b>	<b>7</b>
3.1	Working principle.....	7
3.2	Product identification code.....	8
3.2.1	Motor model code.....	8
3.2.2	Processing ID.....	9
3.3	Technical data.....	10
3.4	Motor interfaces.....	11
3.4.1	Main dimensions.....	11
3.4.2	Shaft connection.....	11
3.4.3	Housing interface.....	12
3.4.4	Torque arm.....	13
3.5	Rotating direction.....	13
3.6	Freewheeling function.....	14
3.7	1-speed : 1N01.....	14
3.8	Piston insert.....	15
3.9	Cylinder block.....	15
3.10	Flushing of the motor case.....	16
3.11	Accessories.....	16
3.11.1	Speed sensor.....	16
3.11.2	Torque arms.....	18
3.11.3	Cross-over relief valve CPV500X.....	19
3.11.4	Freewheeling valve FWV1000.....	20
<b>4</b>	<b>System Design.....</b>	<b>21</b>
4.1	Motor hydraulic circuit.....	21
4.1.1	Simple connection.....	21
4.1.2	Counter pressure operation.....	21
4.1.3	Hydrostatic braking.....	22
4.1.4	Short circuit operation.....	22
4.2	Hydraulic connections.....	23
4.3	Hydraulic fluid.....	23
4.3.1	Hydraulic fluid type.....	23
4.3.2	Hydraulic fluid properties.....	23
4.3.3	Hydraulic fluid cleanliness.....	24
4.4	Operating pressures.....	24
4.4.1	Case pressure.....	24
4.4.2	Working line pressure.....	25

<b>5</b>	<b>Motor Sizing.....</b>	<b>27</b>
5.1	Performance.....	27
5.1.1	Rotating speed and flow rate.....	27
5.1.2	Torque and power.....	27
5.2	Performance charts.....	28
5.2.1	Performance curves.....	28
5.2.2	Pressure loss.....	31
5.2.3	Case leakage.....	32
5.3	Service life.....	32
<b>6</b>	<b>Installation Instructions.....</b>	<b>34</b>
6.1	Mounting the motor.....	34
6.2	Flushing the hydraulic system.....	34
6.3	Commissioning procedure.....	34
<b>7</b>	<b>Operating Instructions.....</b>	<b>36</b>
7.1	Break-in period.....	36
7.2	Use.....	36
7.3	Operating temperature.....	36
7.4	Demounting the motor.....	36
<b>8</b>	<b>Special Instructions.....</b>	<b>38</b>
8.1	Storing the motor.....	38

# 1 General Instructions

## 1.1 About the manual

This manual contains the technical instructions for the Black Bruin X series hydraulic motors. Take these instructions into consideration when planning the use of the product.

All information given in this manual is current and valid according to the information available at the time of publication. The manufacturer reserves the rights to implement changes without prior notice.

Please visit [www.blackbruin.com/downloads](http://www.blackbruin.com/downloads) for the most recent version of this manual. The product datasheets and the 3D-models are available from the manufacturer by request.

## 1.2 Intended use

Black Bruin X series hydraulic motors are designed for industrial use. They can also be used in other applications that use torque for rotary motion.

## 1.3 Warranty

Check the package and the product for transport damage when receiving goods. The package is not meant for long term storage; protect the product appropriately.

Do not dismantle the product. The warranty is void if the product has been disassembled.

The manufacturer is not responsible for damages resulting from misinterpreted, non-compliance, incorrect, or improper use of the product that goes against the instructions given in this document.

## 1.4 Product identification

The product identification data can be found on the identification plate attached to the motor.



Figure 1. Identification plate of the motor.



### Note:

The serial number is also stamped on the motor. All manufacturing data can be found with the serial number.

## 1.5 Publication date

24.04.2024 - This manual is published.

# 1.6 Declaration of incorporation

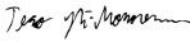
	DECLARATION OF INCORPORATION 1(1)
	2024-04-03
Black Bruin Inc.	
<b>DECLARATION OF INCORPORATION</b> (in accordance with EC Machinery Directive 2006/42/EC, Annex II B)	
Manufacturer	Black Bruin Inc.
Address	Valmetintie 9 FI-40420 Jyskä, FINLAND
Product description	Black Bruin hydraulic motor series: <ul style="list-style-type: none"> <li>▪ <b>BBC</b></li> <li>▪ <b>BB</b></li> <li>▪ <b>B200</b></li> <li>▪ <b>C200</b></li> <li>▪ <b>S</b></li> <li>▪ <b>X</b></li> </ul> <p>We hereby declare that the product(s) specified above is intended to be incorporated into machinery or to be assembled with other machinery to constitute machinery covered by EC Machinery Directive 2006/42/EC, as amended.</p> <p>And that the following harmonised standards have been applied:</p> <ul style="list-style-type: none"> <li>▪ <b>EN ISO 4413:2010</b> (Hydraulic fluid power - General rules and safety requirements for systems and their components)</li> <li>▪ <b>EN ISO 12100:2010</b> (Safety of machinery – General principles for design – Risk assessment and risk reduction)</li> </ul> <p>And furthermore declares that the product(s) covered by this declaration must not be put into service until the final machinery into which it is to be incorporated has been declared in conformity with the provisions of EC Machinery Directive 2006/42/EC.</p> <p>The product(s) must be applied and installed in accordance with all the technical documents applicable to the product(s).</p> <p>This document supersedes all previous releases to this subject.</p>
Place and date	Jyväskylä, 2024-04-03 On behalf of Black Bruin Inc. 
Name	Tero Ylä-Mononen
Title	R&D Manager
<hr/> <small>BLACK BRUIN INC. P.O. Box 633, FI-40101 JYVÄSKYLÄ, FINLAND +358 50 419 3484   info@blackbruin.com   www.blackbruin.com</small>	

## 2 Safety Instructions

The following instructions apply to all procedures associated with the motor. Read these instructions carefully and follow them closely.

- Use necessary personal protective equipment when working with the motor.
- Support the motor properly. Make sure the motor cannot fall over or turn around by accident.
- Use only appropriate equipment and attachments for lifting and transferring the motor.
- Do not use magnetic lifting devices.
- Always use the lifting equipment properly and check the load-bearing capacity.
- Prevent unintended use of the motor during installation and maintenance procedures by preventing pressurization of the hydraulic lines.
- The operating temperature of the motor may be over 60 °C (140 °F), which is hot enough to cause severe burns. Beware of hot hydraulic fluid when disconnecting the hydraulic connections.

### 2.1 Warning symbols

The following symbols are used in this manual:



**Note:**

Useful information.



**Danger:**

Danger of death or injury.



**Attention:**

May cause damage to the product.

## 3 Motor Description

### 3.1 Working principle

X series motors are rotating shaft motors. This means the motor shaft and the cylinder block rotates while the motor is running.

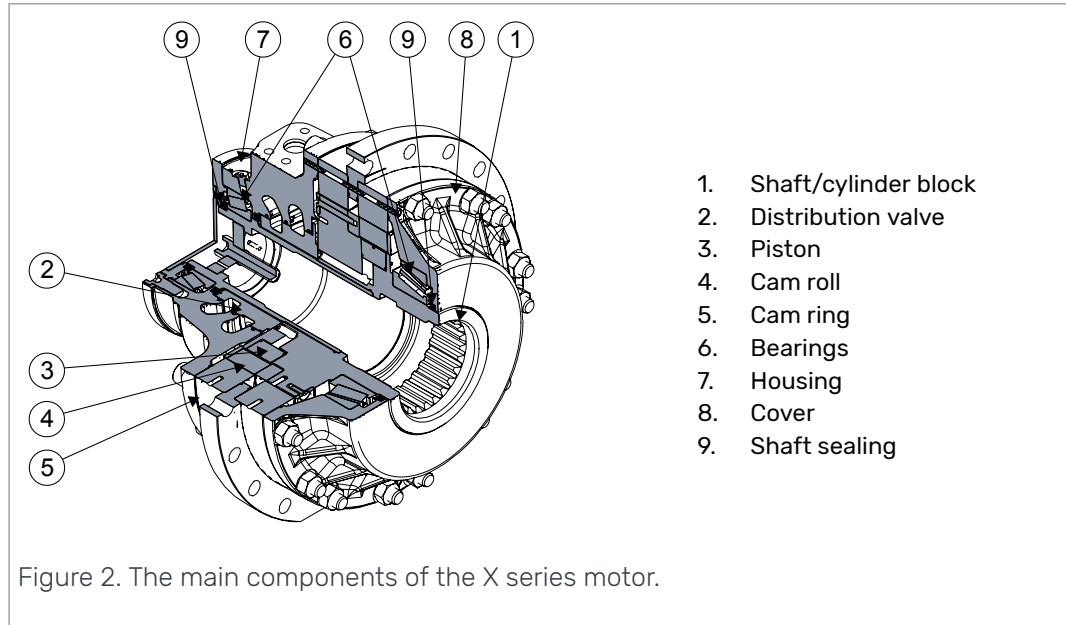

The rotation of the motor is achieved by feeding pressurized hydraulic fluid through the working lines to the distribution valve. The distribution valve directs the flow to the pistons which are on a power stroke. Pressure pushes the pistons and cam rolls outwards against the cam ring on the housing. The waveform of the cam ring transforms the force into torque. When the pistons reach the end of the power stroke, the distribution valve closes the flow to the pistons and switches the pistons to a return stroke. The cam ring pushes the pistons back into the cylinder block preparing them for the next power stroke.

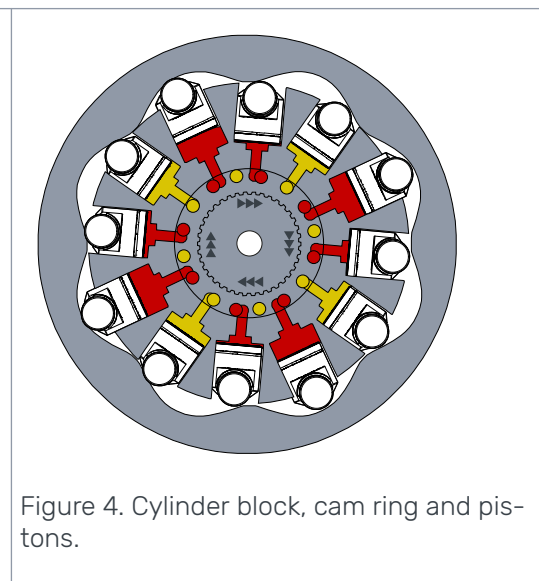
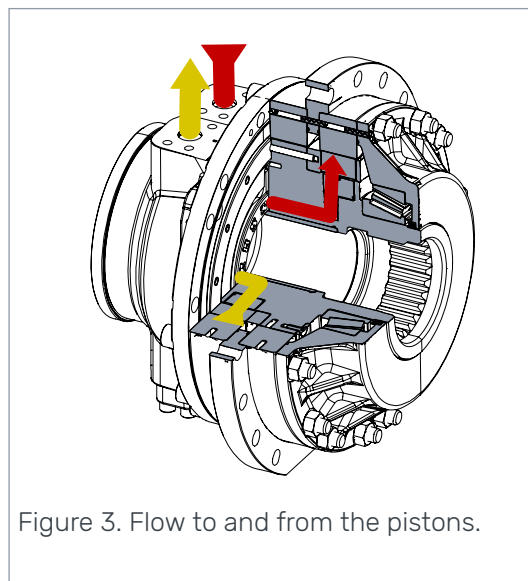

### 3.2 Product identification code

Black Bruin product identification code consists of motor model code and processing ID.

<b>X20-0628-1N01-1A-0-0-1</b>	-	<b>010000</b>
Motor model code	-	Processing ID

#### 3.2.1 Motor model code

<b>MODEL CODE</b>	<b>AAA - BBBB - CCCC - DD - E - F - G</b>
Rotating shaft motors	

<b>A: Frame</b>	<b>AAA - BBBB - CCCC - DD - E - F - G</b>	<b>X20</b>
X series frames	<u>X20</u>	•

<b>B: Displacement</b>	<b>AAA - BBBB - CCCC - DD - E - F - G</b>	<b>X20</b>
X20 displacements	<u>0251</u> : 2512 ccm/rev	•
	<u>0314</u> : 3140 ccm/rev	•
	<u>0402</u> : 4020 ccm/rev	•
	<u>0502</u> : 5024 ccm/rev	•
	<u>0628</u> : 6280 ccm/rev	•
	<u>0754</u> : 7543 ccm/rev	•
	<u>0880</u> : 8800 ccm/rev	•

<b>C: Displacement control</b>	<b>AAA - BBBB - CCCC - DD - E - F - G</b>	<b>X20</b>
1-speed	<u>1N01</u> : Fixed displacement, double work ports	•

<b>D: Shaft type</b>	<b>AAA - BBBB - CCCC - DD - E - F - G</b>	<b>X20</b>
Internal splines	<u>1A</u> : DIN5480-N140	•

<b>E: Housing type</b>	<b>AAA - BBBB - CCCC - DD - E - F - G</b>	<b>X20</b>
Mounting connection	<u>0</u> : PCD 520, 17xD22	•
	<u>1</u> : PCD 560, 21xD22	•

<b>F: Piston inserts</b>	<b>AAA - BBBB - CCCC - DD - E - F - G</b>	<b>X20</b>
Piston inserts	<u>0</u> : Standard	•
	<u>1</u> : Slow speed	•

<b>G: Cylinder block</b>	<b>AAA - BBBB - CCCC - DD - E - F - G</b>	<b>X20</b>
Cylinder block	<u>0</u> : Standard	•
	<u>1</u> : Reinforced	•

<b>Code example</b>	<b><u>X20</u> - <u>0628</u> - <u>1N01</u> - <u>1A</u> - <u>0</u> - <u>0</u> - <u>1</u></b>
	<b>A - B - C - D - E - F - G</b>
A =	The frame of the motor is "X20".



<b>Code example</b>	<b>X20 - 0628 - 1N01 - 1A - 0 - 0 - 1</b>
	<b>A - B - C - D - E - F - G</b>
B =	The displacement of the motor is 6280 ccm/rev.
C =	1-speed, fixed displacement, double work ports.
D =	Shaft with internal splines N140.
E =	Mounting connection with pitch circle diameter 520mm and 17xD22 holes
F =	Standard piston inserts.
G =	Reinforced cylinder block.

### 3.2.2

### Processing ID

<b>X SERIES PROCESSING ID</b>		<b>R M S P D T</b>
<b>R M S P D T</b>	<b>Lubrication</b>	<b>Definition of factory lubrication</b>
0	= Default / Not defined	
<b>R M S P D T</b>	<b>Painting</b>	<b>Definition of the painted surfaces</b>
0	= No painting	-Motors are protected from corrosion.
1	= Painted	- <sup>1)</sup>
<b>R M S P D T</b>	<b>Protection</b>	<b>Definition of the protection for storage/trans- portation</b>
0	= Default / Not defined <sup>2)</sup>	
<b>R M S P D T</b>	<b>Packaging</b>	<b>Definition of the motor package</b>
0	= Default / Not defined <sup>3)</sup>	
<b>R M S P D T</b>	<b>Documents</b>	<b>Definition of the printouts to be attached to the delivery</b>
0	= Default / Not defined	
<b>R M S P D T</b>	<b>Testing</b>	<b>Definition of the testing and reporting</b>
0	= Default / Not defined <sup>4)</sup>	
<b>Code example</b>	<b>0 1 0 0 0 0</b>	
	<b>R M S P D T</b>	
R =	The seal protector of the motor is not filled with lubricant.	
M =	Prime coating. The shaft and hub interfaces of the motor are unpainted.	
S =	Pressure openings and threaded holes of the motor are protected according to general practices of the manufacturer.	
P =	The motor is packaged according to general practices of the manufacturer.	
D =	The documentation delivered with the motor is according to general practices of the manufacturer.	
T =	The motor is tested according to general practices of the manufacturer.	

<sup>1)</sup> Prime coating: Black, paint thickness >80 µm.

## Motor Description

2) Working lines are plugged with metal covers. Other pressure openings and threaded holes are capped with plastic fittings. Hydraulic fluid is drained out.

3) Delivery on wooden pallet or in plywood box.

4) The manufacturer keeps test records of every manufactured motor.

### 3.3 Technical data

TECHNICAL DATA	X20						
<b>Displacement [ccm]</b>	2512	3140	4020	5024	6280	7543	8800
<b>Maximum torque [Nm] <sup>1)</sup></b>							
theoretical	15990	19980	25590	31980	39970	48020	56020
with 100 bar	3990	4990	6390	7995	9990	12000	14000
<b>Max. operating power [kW]</b>	280						
<b>Max. rotating speed [rpm] <sup>1)</sup></b>	380			312	250	208	178
at freewheeling	400						
<b>Min. rotating speed [rpm] <sup>2)</sup></b>	2/0,5						
<b>Max. working pressure [bar]</b>							
peak pressure <sup>3)</sup>	400/380					400/330	400/300
intermittent <sup>3) 4)</sup>	380/350					380/310	380/280
<b>Max. case pressure [bar]</b>							
average	2						
intermittent <sup>4)</sup>	10						
<b>Flushing flow [l/min]</b>							
recommended	8-10						
maximum	60						
<b>Weight [kg]</b>	315 -325						

<sup>1)</sup> These values correspond to the displacement values in the same column.

<sup>2)</sup> Option F ([3.8 Piston insert](#)): Standard / Slow speed.

<sup>3)</sup> Option G ([3.9 Cylinder block](#)): Reinforced / Standard

<sup>4)</sup> Intermittent operation: permissible values for maximum of 10% of every minute.

### 3.4 Motor interfaces

#### 3.4.1 Main dimensions

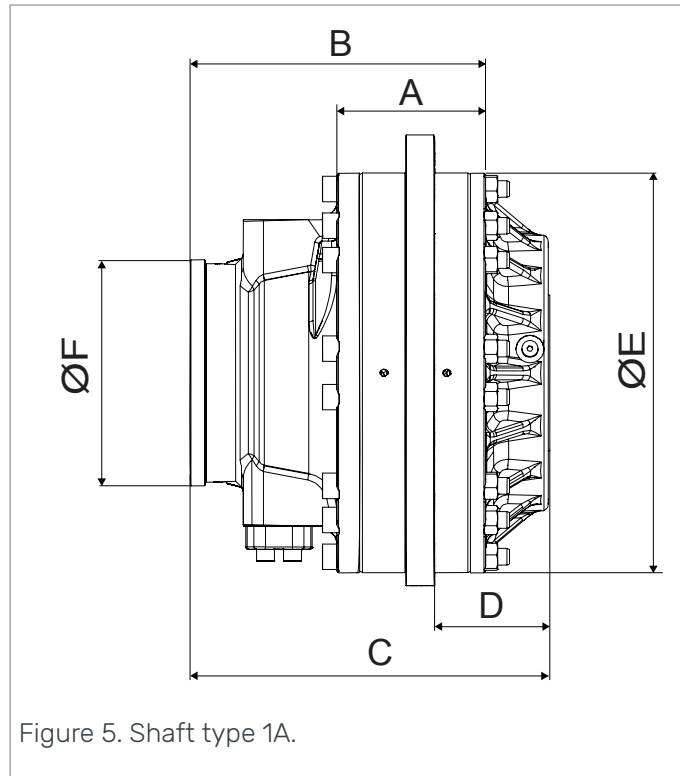

MOTOR TYPE	SHAFT TYPE	MAIN DIMENSIONS [mm]					
		A	B	C	D	E	F
X20	1A	175	347,5	421	135,5	470,5	266,5

#### 3.4.2 Shaft connection

AAAAA - BBBB - CCCC - **DD** - E - F - G

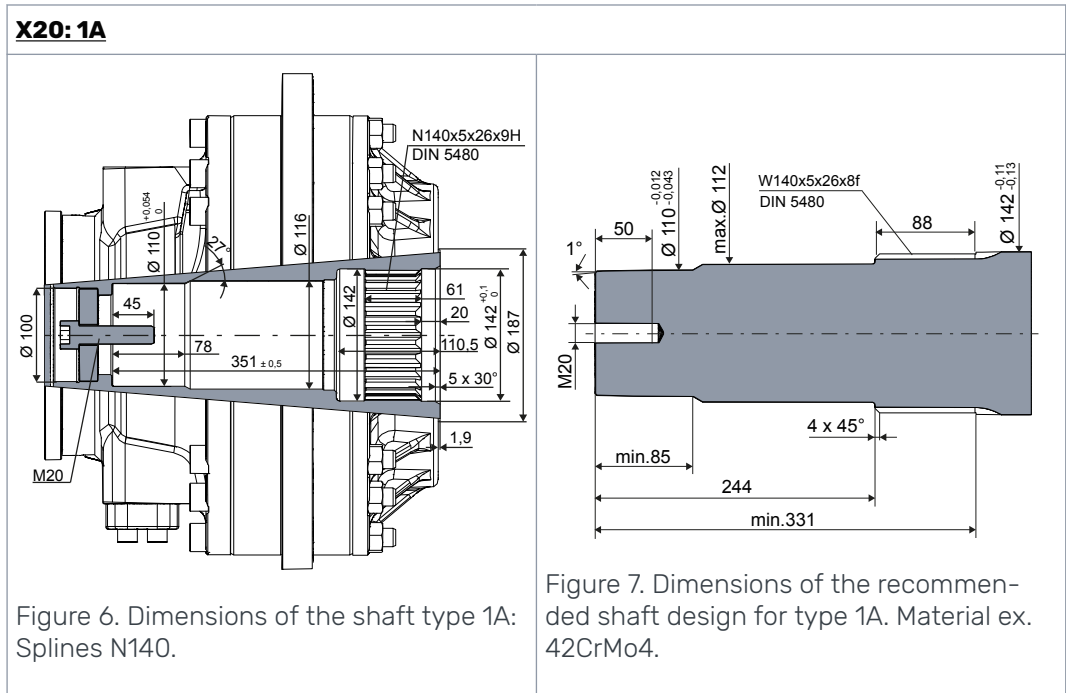

### 3.4.3 Housing interface

AAAAA - BBBB - CCCC - DD - **E** - F - G

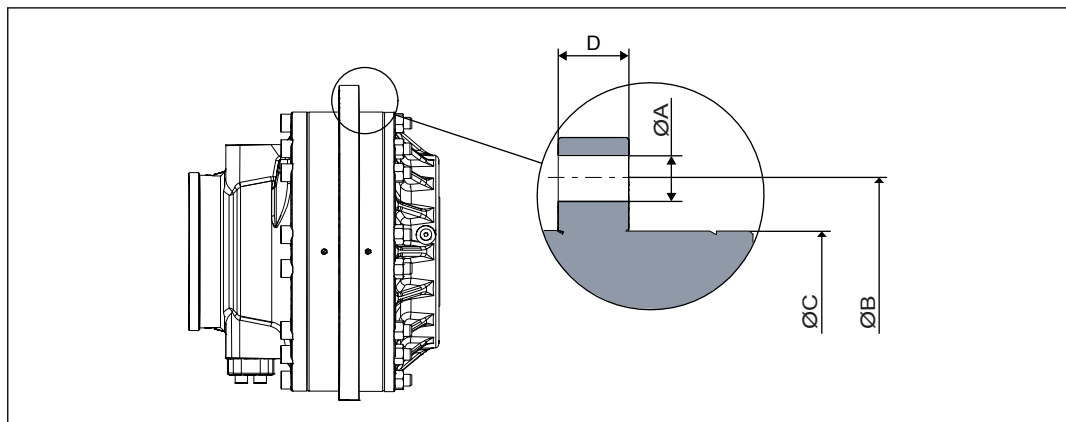

Figure 8. Dimensions of the housing interface.

INTERFACE DIMENSIONS			
Housing type		PCD 520	PCD 560
A	[mm]	22	22
B	[mm]	520	560
C	[mm]	470	510
D	[mm]	34	34

More detailed information and dimensions can be found on the product datasheet.



**Note:**

The attachment screws are not included in the motor delivery. Ensure correct dimensioning and availability of the fastening screws.

### 3.4.4 Torque arm

The motor can be mounted to the application with the torque arm.

The length of the torque arm affects the radial force applied to the motor and thus the service lifetime of the bearings.

For torque arm mounting, the splines of the shaft connection must be greased or in oil.

When using a double ended torque arm there would not be a radial load applied to the motor due the torque.

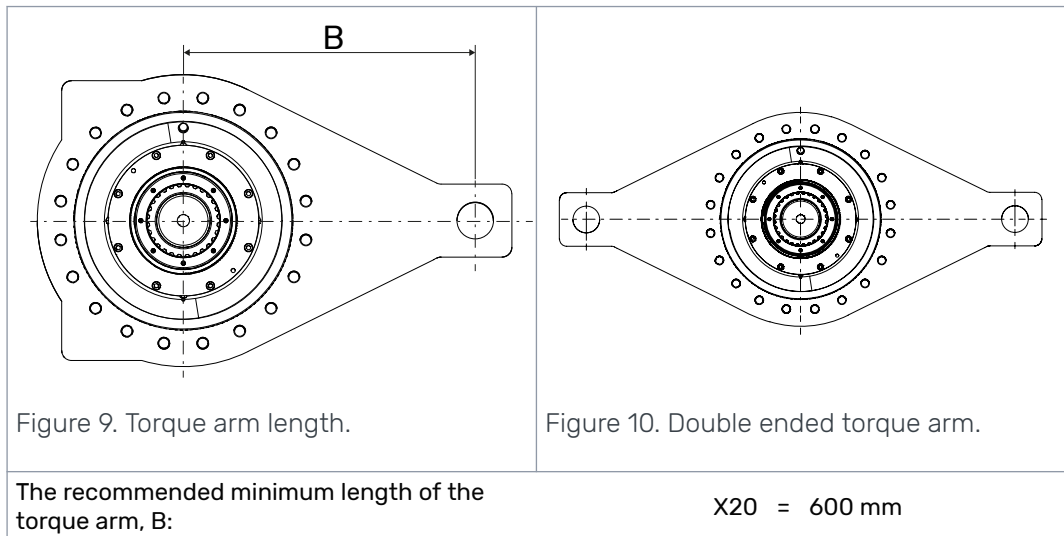

### 3.5 Rotating direction

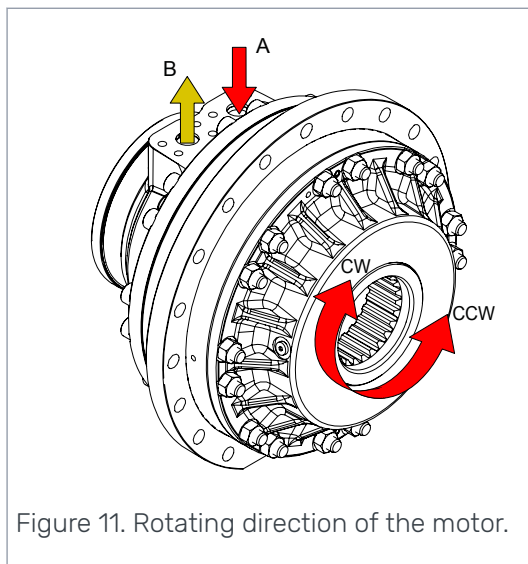

The rotating direction of the motor is defined as the rotating direction of the shaft viewed from the front of the motor.

The rotating direction of the motor and the flow direction in the working lines is given in the table below.

## Motor Description

Table 1: Rotating direction and flow direction.

ROTATING DIRECTION	Flow direction	
	A → B	B → A
1N01	CW	CCW

### 3.6 Freewheeling function

Freewheeling of the X series motors can be done by pressurizing the casing, when the case pressure pushes the pistons into the cylinder block. The case pressure must be at least 0.5 bar higher than the pressure on the working lines (A and B). The maximum case pressure must not be exceeded. The permissible freewheeling speed and the maximum case pressure can be found in the technical data (see [3.3 Technical data](#)).



#### Attention:

Any pressure in the working lines (A and B) or loss of case pressure during the freewheeling pushes the pistons out of the freewheeling position. This causes a clattering noise when the pistons hit the cam ring.

Constant clattering of the pistons may cause premature wear or failure of the motor.

#### ENGAGING THE MOTOR

Make sure that the motor is not running when engaging the motor, unless the FWV1000 valve is used. When engaging the motor, the pressure in the working lines must be less than 100 bar to prevent excessive pressure peak in casing, which may damage the shaft seals.

### 3.7 1-speed : 1N01

AAAAA - BBBB - <b>CCCC</b> - DD - E - F - G
---

Displacement control selection 1-speed means the motor has a fixed displacement. These motors are known as 1-speed motors and are always in full displacement during operation.

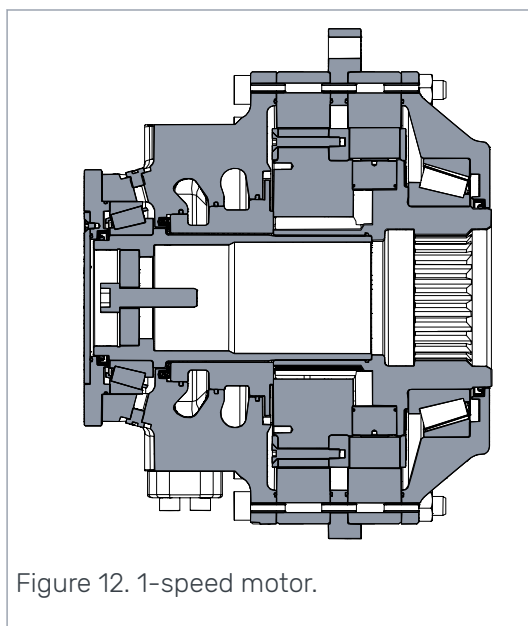

Figure 12. 1-speed motor.

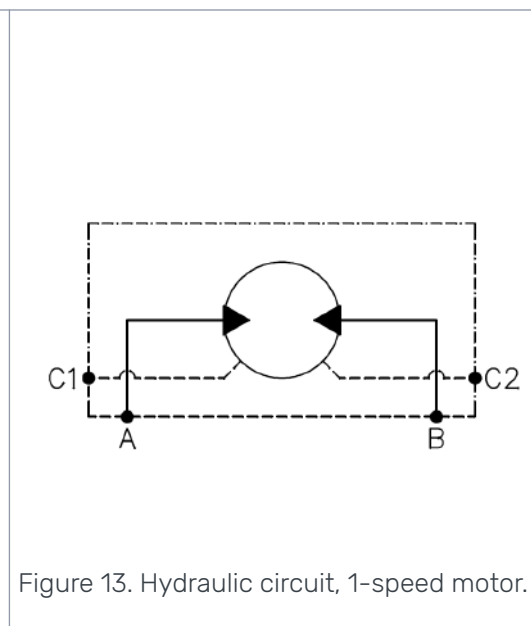

Figure 13. Hydraulic circuit, 1-speed motor.

### 3.8 Piston insert

AAAAA - BBBB - CCCC - DD - E - **F** - G

It is recommended to choose piston insert (F) option 1:

- If rotating speed is constantly under 5 rpm
- If starting efficiency is in high importance, e.g. in winches.

Note that with piston insert option 1 the maximum oil temperature is +75°C. For rotating speeds over 5 rpm and for high power applications the standard piston insert is recommended.

### 3.9 Cylinder block

AAAAA - BBBB - CCCC - DD - E - F - **G**

With reinforced cylinder block option you can have higher work pressure rating, see table below.

Displacement option	Maximum work pressure (peak), bar	
	Standard	Reinforced
0251	380	400
0314	380	400
0402	380	400
0502	380	400
0628	380	400
0754	330	400
0880	300	400

### 3.10 Flushing of the motor case

All the X series motors are equipped with multiple case flushing line ports (C1). The flushing line is an extra case line for cooling the motor. The C2 port, which is not used for case drain, can also be used for flushing.

The motor should be cooled to avoid high temperature in the motor case. High temperature can reduce the performance and the lifetime of the motor.

The motor case must be flushed (see recommended flushing flow rate in [3.3 Technical data](#)) in all continuous duty applications where the output power is over the 50% of maximum power of the motor. The motor case must be flushed also if in application the motor oil temperature exceed the maximum operating temperature (see [7.3 Operating temperature](#)).

### 3.11 Accessories

#### 3.11.1 Speed sensor

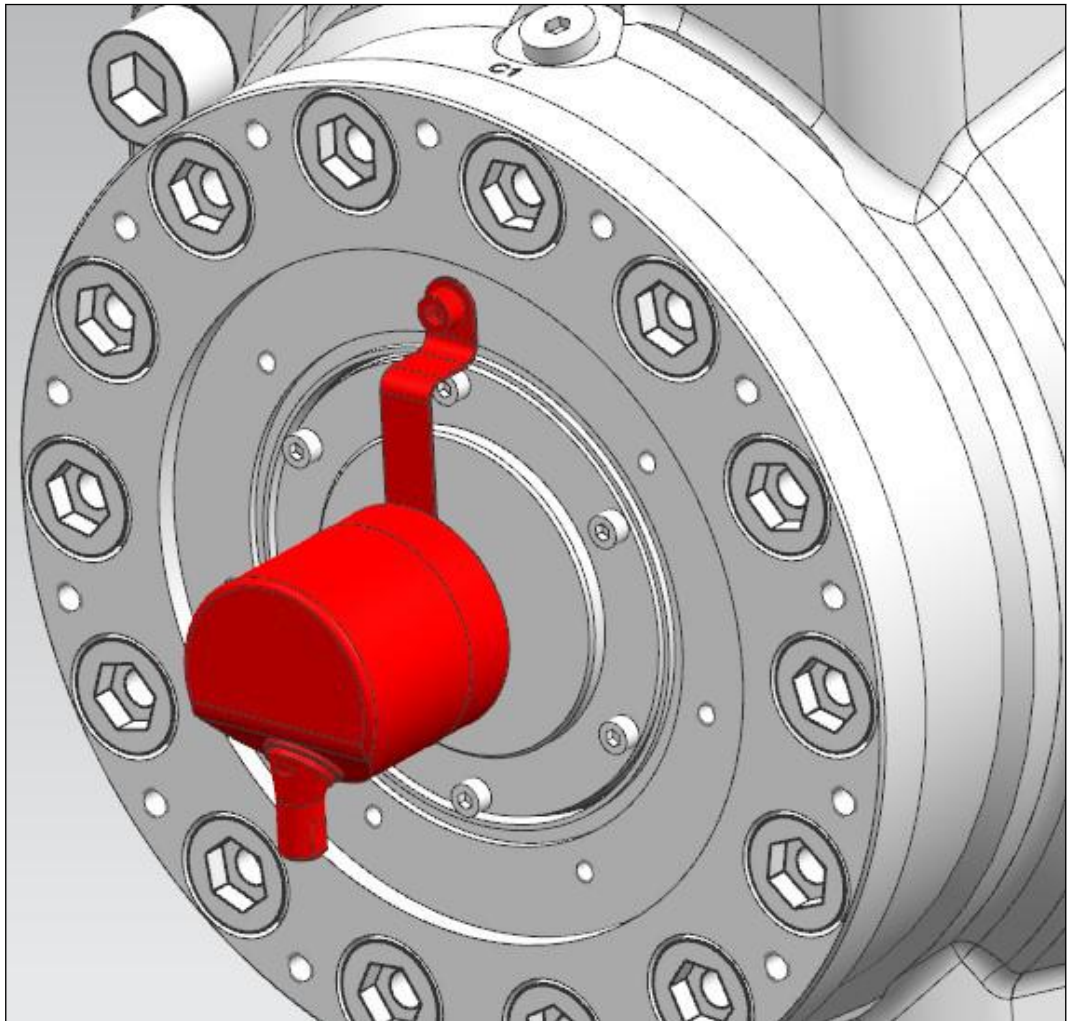

It is possible to use the speed sensor with all X series motors. The speed sensor can be ordered separately.

The speed sensor of the X series motors is incremental magnetic encoder and the pulse rate is 1024ppr. Technical data of the speed sensor can be found from the table below.



<b>Pulses per revolution</b>	1024
<b>Supply voltage</b>	4,75–30 V
<b>Electrical protection</b>	Reverse polarity, short circuit, protection class III
<b>Current consumption</b>	150mA max.
<b>Output type</b>	Pulse line A and B (90° phase difference)
<b>Signal type</b>	HTL
<b>Frequency range</b>	0 to 1000 kHz
<b>Protection rating</b>	On the housing: IP67 On the shaft IP65
<b>Temperature range</b>	-40 - 85 °C
<b>Shock resistance</b>	100 g
<b>Vibration resistance</b>	20 g
<b>Material</b>	Flange: aluminium Housing and shaft: stainless steel
<b>Max. cable length</b>	100 m
<b>Connector type</b>	M12x1, radial, can also be used axially

<b>Connections</b>	
Pin number	Function
1	Power supply
2	Signal A
3	Ground
4	Z/O-pulse (90 degrees)
5	Signal B
Pulse diagram Direction of rotation clockwise (looking at the shaft)	

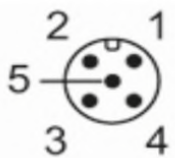
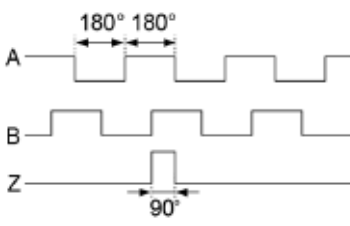
More detailed sensor installation instructions; see the installation manual of the speed sensor.

### 3.11.2 Torque arms

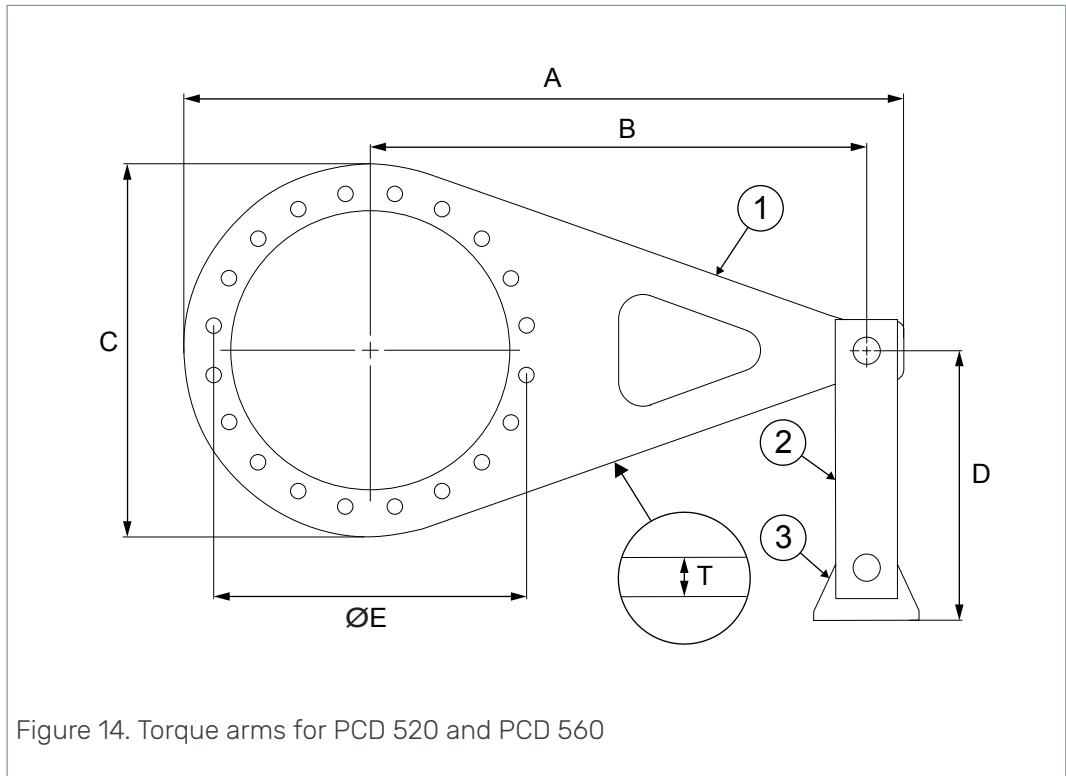

	<b>PCD 520</b>	<b>PCD 560</b>
A	1160 mm	1160 mm
B	800 mm	800 mm
C	600 mm	600 mm
D	435 mm	435 mm
E	520 mm	560 mm
T	40 mm	40 mm

<b>Item numbers</b>		
	<b>PCD 520</b>	<b>PCD 560</b>
1	Torque arm N11996	Torque arm N11998
2	Link N11929	
3	Anchor N11930	

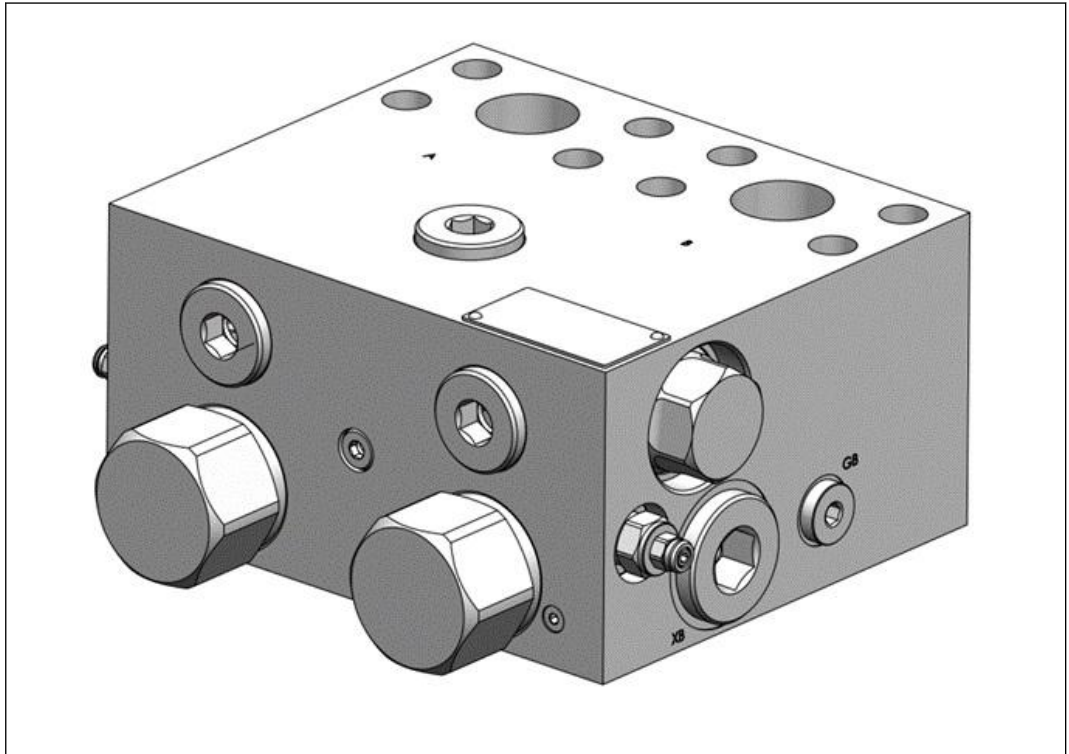
**3.11.3****Cross-over relief valve CPV500X**

CPV500X valve provides cross line relief and cavitation protection.

Features:

- rated flow 500 lpm
- standard pressure setting 320 bar
- mounted directly on motor's work ports
- protects the motor from high pressure peaks.

For more information, refer to the datasheet.

### 3.11.4 Freewheeling valve FWV1000

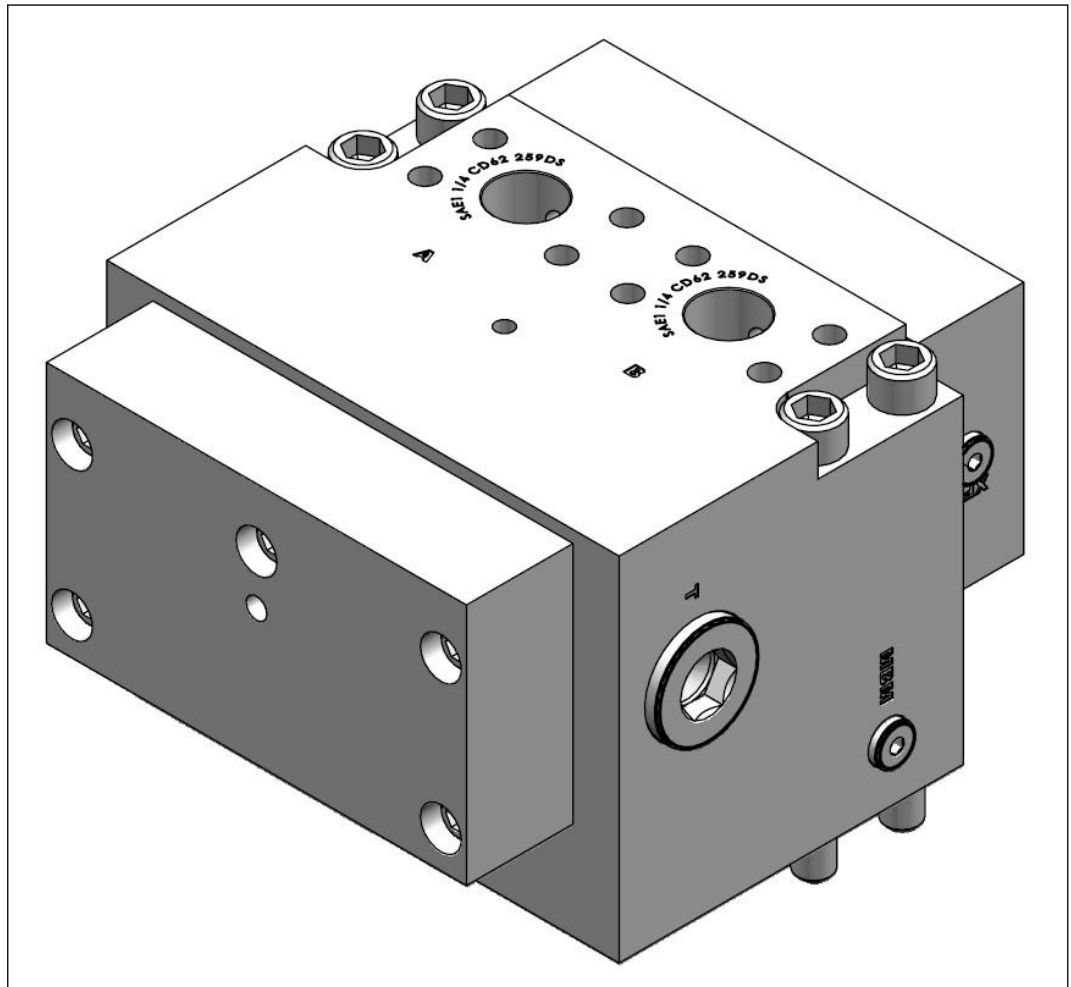

FWV1000 valve provides free circulation or freewheeling functions.

- Maximum pressure up to 420 bar
- Flow up to 1000 l/min
- Mounted directly on motor with adapter
- Shifting from drive mode to the freewheeling and from freewheeling to the drive mode can be done during the rotation.

For more information, refer to the datasheet.

## 4 System Design

### 4.1 Motor hydraulic circuit

#### 4.1.1 Simple connection

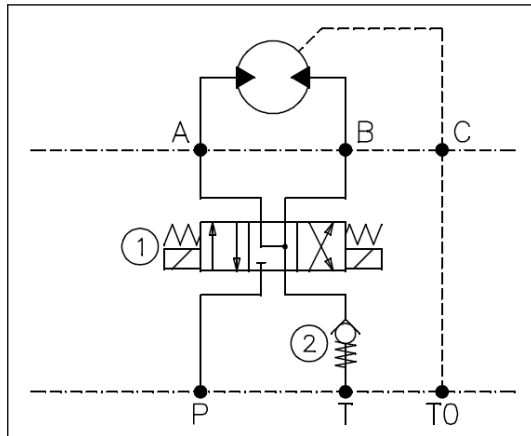

Figure 15. A simple motor hydraulic circuit in an open loop hydraulic system.

In an open loop hydraulic system the hydraulic circuit of the motor is usually implemented roughly as in the figure above.

- Select the operating direction with the directional control valve (1) by applying the working pressure (P) to the other working line (A or B).
- The minimum pressure (see [4.4.2 Working line pressure](#)) required in the return line (T) is created with the cracking pressure of the check valve (2).
- The case drain line port (C) is connected to the system reservoir (T0) as directly as possible.



**Attention:**

The case drain line of the motor must always be connected to a reservoir, even during freewheeling. The case pressure of the motor may rise significantly, if the motor is completely plugged during use.



**Note:**

Using the motor on a closed loop hydraulic system is different from the open loop system. The closed loop system is more complex, but enables more functions, such as hydrostatic braking, series connection and counter pressure operation.

#### 4.1.2 Counter pressure operation

Counter pressure operation means using the motor with high back pressure in the return line.

The counter pressure operation affects the torque output of the motor due to decreased pressure difference over the working lines.

High counter pressure affects also to the motor efficiency.



**Attention:**

Make sure the combined pressure in the working lines does not exceed the permissible values of the working pressure during counter pressure operation.

Counter pressure operation is not recommended for X series motors, because high back pressure stresses the motor more than usual operation.

### 4.1.3 Hydrostatic braking

Hydrostatic braking means using the output torque of the motor to decelerate the speed. The output torque is generated by closing the return line of the motor, in which case a working pressure will form in the return line. The minimum pressure and feed flow must be maintained in the feed line of the motor during hydrostatic braking.



**Note:**

The hydrostatic braking requires an active hydraulic fluid supply.



**Danger:**

Do not use the hydrostatic braking without relief valves in the working lines. When an external load is rotating the motor, the hydraulic pressure may increase indefinitely. This leads to danger if a hydraulic hose or component breaks under high pressure.

### 4.1.4 Short circuit operation

Short circuit operation means connecting the return flow of the motor directly to the feed line of the motor.

Short circuit operation is needed if the motor must be rotated faster than the hydraulic system can supply and freewheeling the motor is not possible (see [3.6 Freewheeling function](#)).

Make sure the minimum pressure is maintained in both working lines of the motor during short circuit operation.



**Note:**

The short circuit operation requires an active hydraulic fluid supply.



**Attention:**

Make sure the motor does not overheat during short circuit operation.

## 4.2 Hydraulic connections

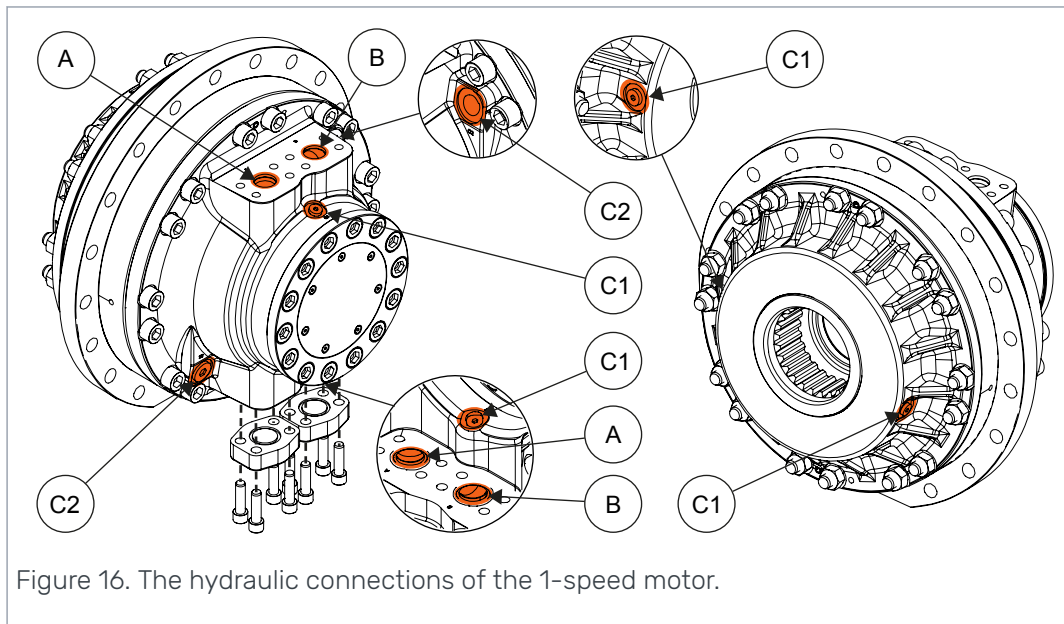

Figure 16. The hydraulic connections of the 1-speed motor.

- **WORKING LINE PORTS (A and B)**  
The working lines, aka the feed and return lines of the motor are the high pressure lines meant for running the motor. There is an option to use double work ports by removing the flanges from the downwards ports.
- **FLUSHING LINE PORTS (C1)**  
The flushing line is the motor housing flushing inlet line.
- **CASE DRAIN LINE PORTS (C2)**  
The case drain line is the return line from the housing cavity. For the case drain line the topmost C2 port must be used, depending on the position of the motor in the application.



**Note:**

More detailed information and dimensioning can be found on the product datasheet.

## 4.3 Hydraulic fluid

### 4.3.1 Hydraulic fluid type

Black Bruin hydraulic motors are designed to work with hydraulic fluids based on mineral oil. Consider the following requirements when choosing hydraulic fluid:

- Hydraulic oils in accordance with ISO 6743-4 are recommended to be used.
- Motor oils in accordance with API-grades SF, SG, SH and SL may also be used.
- Fire resistant hydraulic fluids HFB and HFC or similar may be used under certain circumstances.

### 4.3.2 Hydraulic fluid properties

Requirements concerning the hydraulic fluid properties:

- The recommended fluid viscosity range for constant use is 25 - 50 cSt.
- The minimum permissible intermittent viscosity is 15 cSt.
- The maximum permissible viscosity during motor startup is 1000 cSt.
- The viscosity index must be at least 100.
- The water content of hydraulic oil should be less than 500 ppm (0,05 %).
- The hydraulic fluid must reach score 10 on a wear protection test FZG A/8,3/90 in accordance with ISO 14635-1 (DIN 51354)
- The effect of the additives improving the viscosity index can decrease during operation.



**Note:**

Temperature has a significant effect on the viscosity and the lubricating capability of the hydraulic fluid. Take into consideration the real operating temperature when defining the fluid viscosity.

The need for service and the overall service life may be improved by using hydraulic fluids with higher viscosity. In addition higher viscosity may improve the running smoothness.

### 4.3.3 Hydraulic fluid cleanliness

Hydraulic fluid must fulfill cleanliness level 18/16/13 in accordance with ISO 4406 (NAS 1638 grade 7).



**Note:**

The purity of the hydraulic fluid has a significant effect on the need for service and the overall service life of the motor.

## 4.4 Operating pressures

### 4.4.1 Case pressure

The case pressure of the motor affects the lifetime of the sealing. It is recommended to maintain as low case pressure as possible.

When the motor is running, the permissible average case pressure is 2 bar and the highest permissible intermittent case pressure is 10 bar.

When the motor is not running, the highest permissible constant case pressure is 10 bar.



**Attention:**

Running the motor with higher than allowed case pressure shortens the service life of the motor.



**Note:**

The lifetime of the sealing may be improved with an accumulator, which cuts the pressure peaks that are higher than the pre-charge pressure of the accumulator.

Recommended pre-charge pressure is 2 bar and the displacement should be about 25 % of the motor displacement. The accumulator should be connected to the case drain line port as close to the motor as possible.



## 4.4.2 Working line pressure

### WORKING PRESSURE

The working pressure is the high pressure that generates the output torque of the motor. The following values for the working pressure are in the technical data (see [3.3 Technical data](#)):

- PEAK PRESSURE

The value of the peak pressure is the maximum allowed value of the working pressure. Make sure the working pressure does not exceed this value under any circumstances.

- INTERMITTENT PRESSURE

The value of the intermittent pressure is a permissible value of the working pressure for a reference period of one minute (1 min). The working pressure may exceed this value for 10 % of the time during the reference period (for 6 seconds).

### MINIMUM PRESSURE

The minimum pressure is a low pressure required in the working lines, which ensures the motor stays engaged when running. The motor is engaged when the pistons of the motor stay constantly connected to the cam ring.

The required minimum pressure depends mainly on the flow rate in the working lines.

The minimum pressure is maintained with back pressure or charge pressure. Type of the hydraulic system affects the implementation.

- BACK PRESSURE

In open loop hydraulic system the minimum pressure may be done with back pressure. The back pressure is usually generated by a suitable check valve with cracking pressure.

- CHARGE PRESSURE

In closed loop hydraulic system the charge pressure is usually used as the minimum pressure.

In open loop hydraulic system the charge pressure may be done by a suitable pressure reducing valve.

When the motor is used in braking mode, value for required minimum pressure can be found in the following figure. Required minimum pressure is 50% of this value, if motor works in driving mode only. In this case pressure may not be lower than 2 bar.

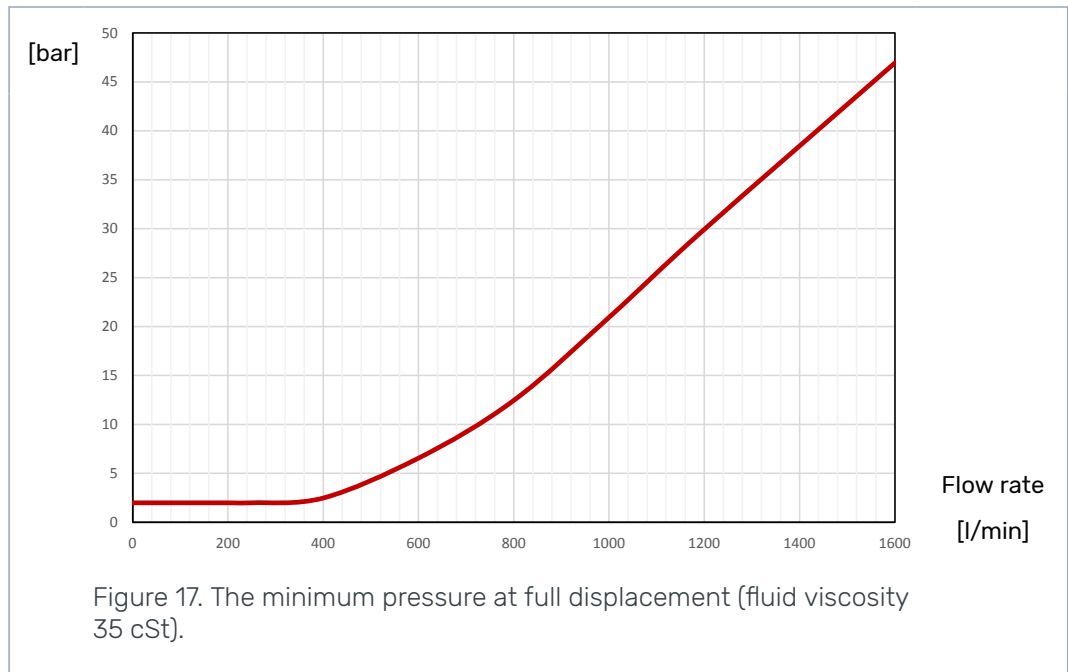

**Attention:**

Too low pressure in the working lines causes the pistons to disconnect from the cam ring when the motor is running. The effect of this is a clattering noise when the pistons hit the cam ring again.

Constant use with too low working line pressure may cause premature wear or failure of the motor.

## 5 Motor Sizing

### 5.1 Performance

#### 5.1.1 Rotating speed and flow rate

Rotating speed of the motor and required flow rate may be calculated with the following equations:

<u>ROTATING SPEED</u>	
$\text{RPM} = 1000 \cdot \frac{Q}{V}$	RPM = rotating speed [rpm] V = displacement [ccm] Q = flow rate in working lines [l/min]
<u>FLOW RATE</u>	
$Q = \frac{\text{RPM} \cdot V}{1000}$	



**Note:**

Due to motor dynamics, a constant smooth operating speed of under 1 rpm may be difficult to achieve.

#### 5.1.2 Torque and power

##### Torque

The output torque of the motor is generated by the pressure difference of the working lines (pressure difference between ports A and B)

The output torque of the motor may be estimated with the following equations:

<u>MAXIMUM TORQUE</u>	
$T_{\text{max}} = 0,01592 \cdot V \cdot \Delta p$	T = torque [Nm] V = displacement [ccm] $\Delta p$ = pressure difference [bar]

##### Power

The operating power of the motor should be determined for all operating conditions. The operating power may be calculated with the following equation:

$P = \frac{Q \cdot p_w}{600}$	P = power [kW] Q = flow rate in working lines [l/min]
or	RPM = rotating speed [rpm] V = displacement [ccm]
$P = \frac{V \cdot \text{RPM} \cdot p_w}{600\,000}$	$p_w$ = working pressure [bar]



**Note:**

Rough estimate of the operating power may be checked by dividing the available hydraulic power between the motors.

The allowed performance values can be found in the technical data (see [3.3 Technical data](#)) and performance charts (see [5.2 Performance charts](#)).

## 5.2 Performance charts

### 5.2.1 Performance curves

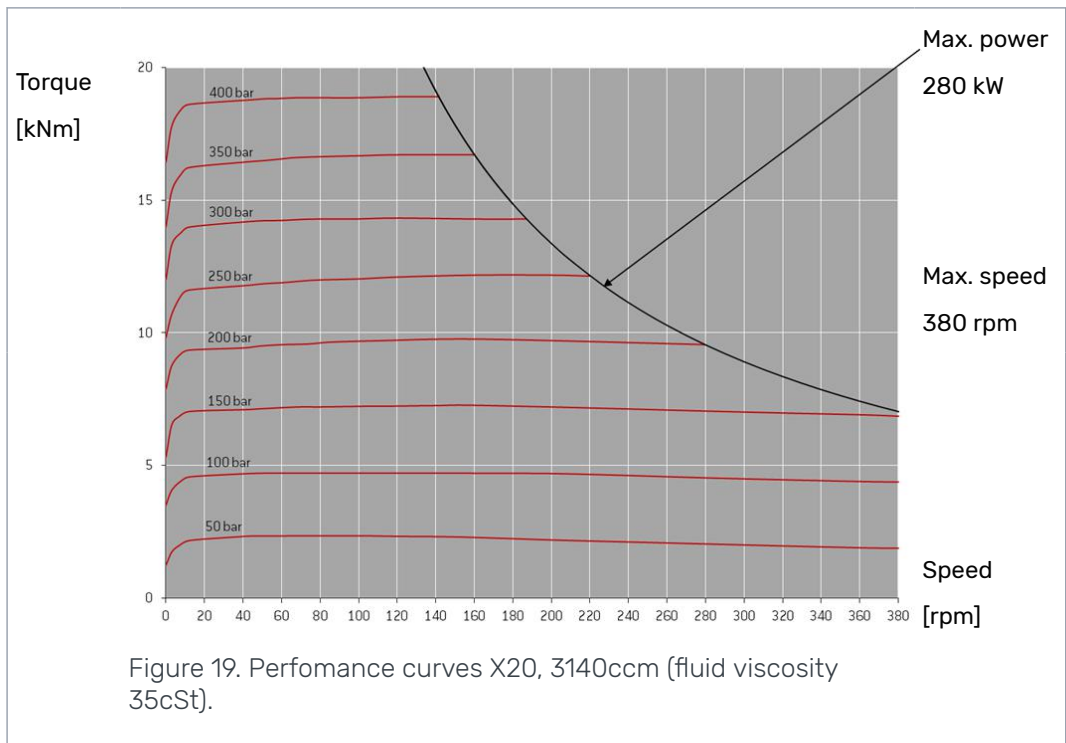
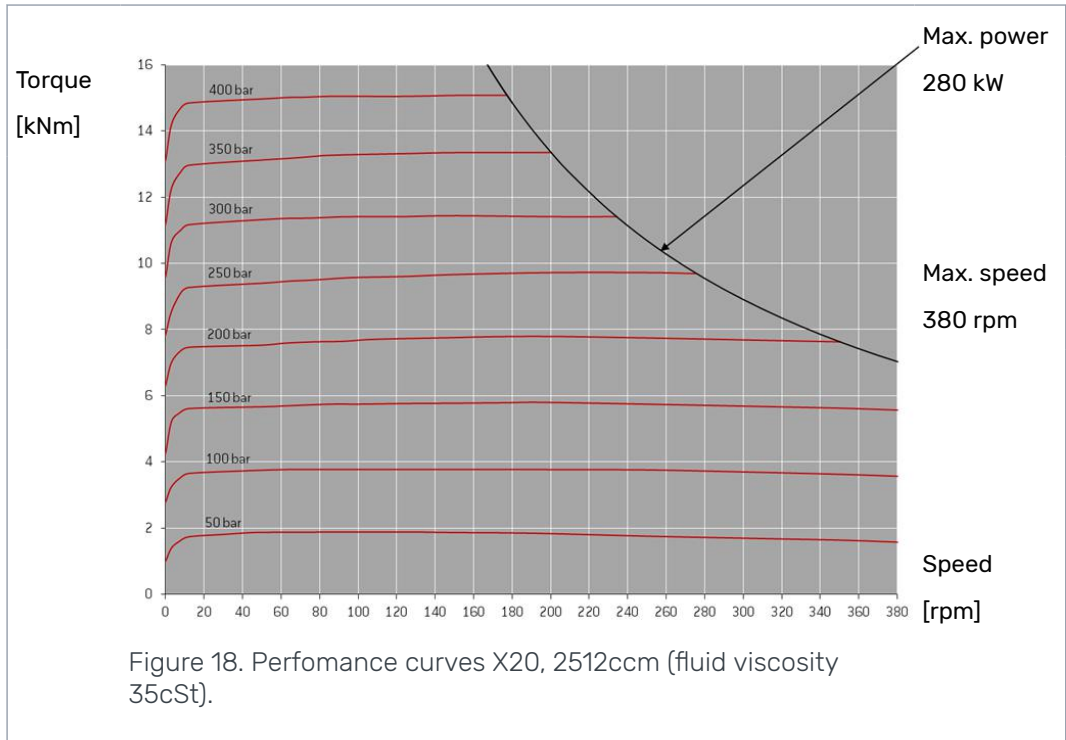

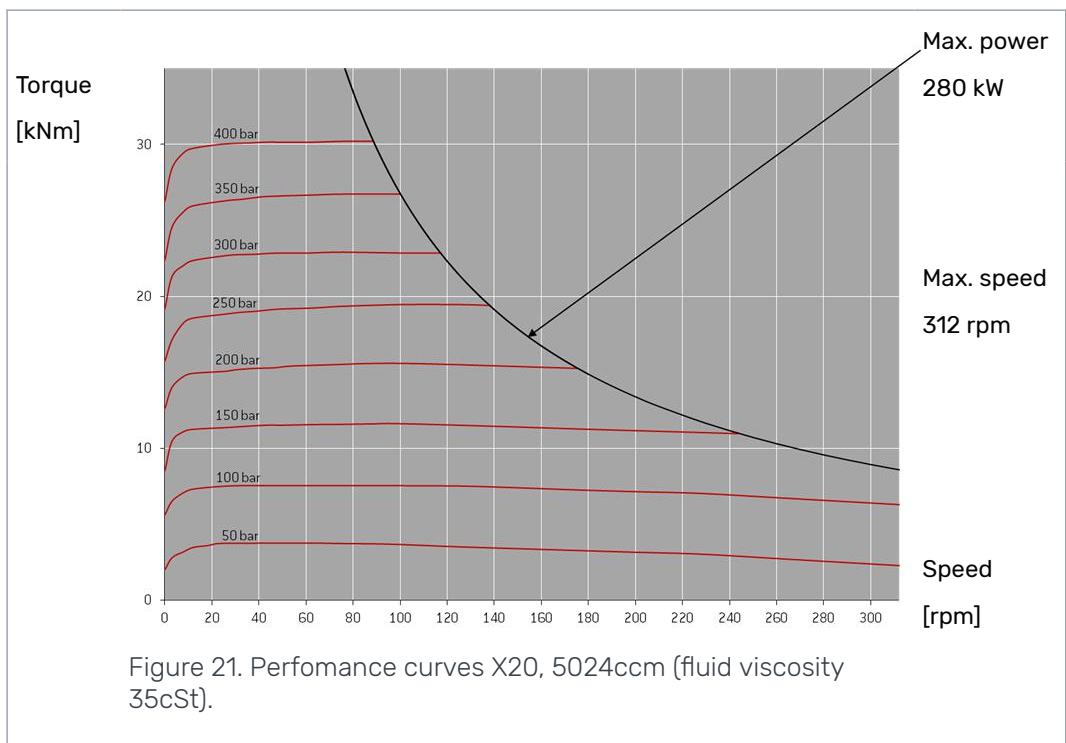
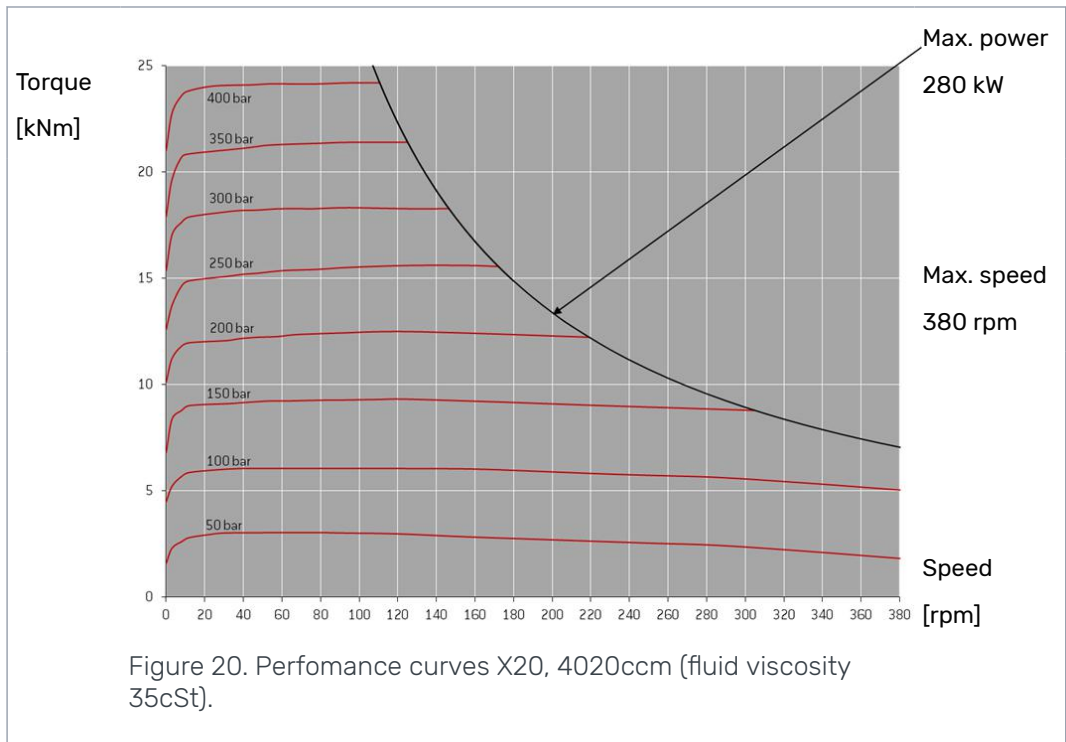

# Motor Sizing

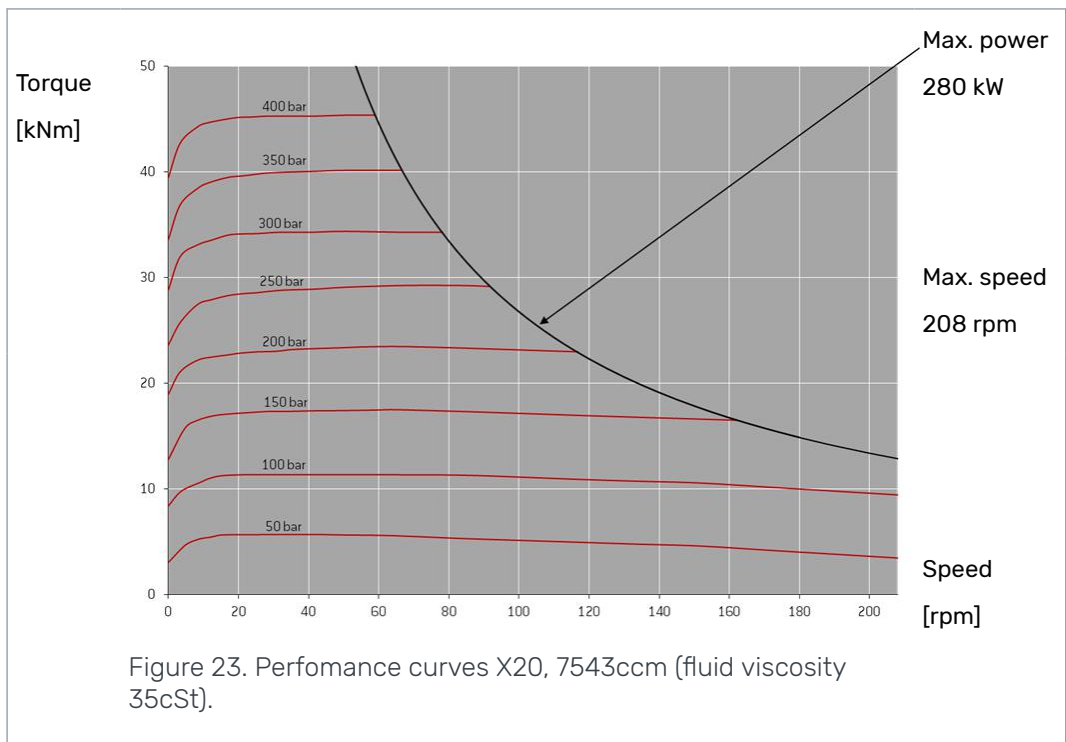
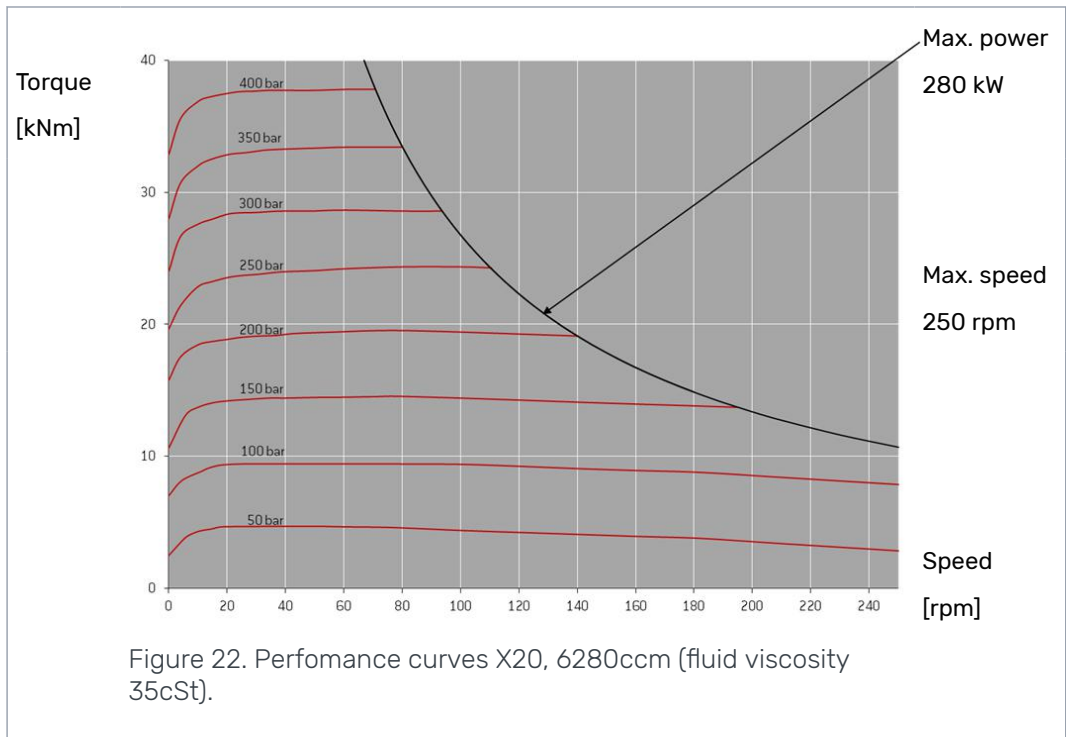

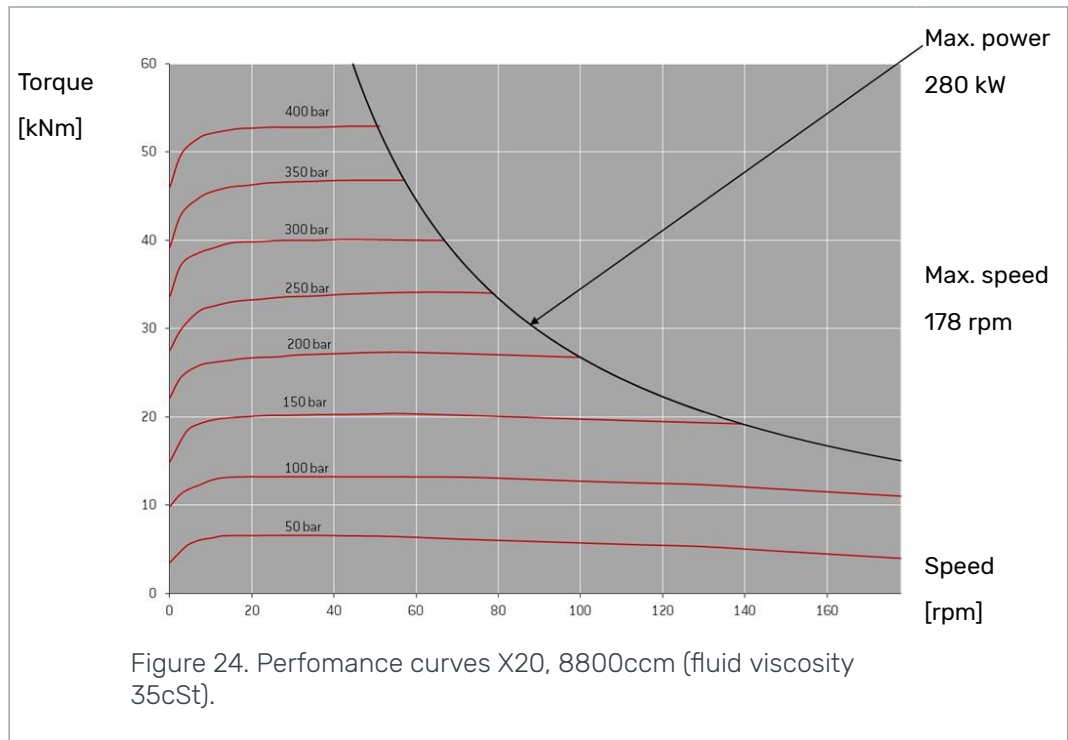

### 5.2.2

#### Pressure loss

The figures below apply to all X series motors.



### 5.2.3 Case leakage

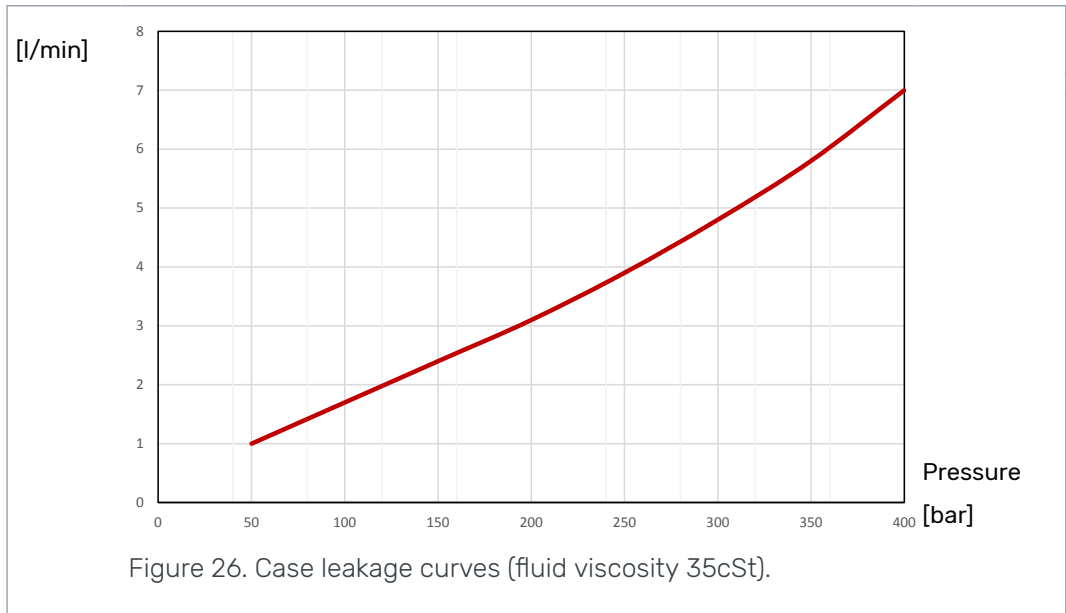

### 5.3 Service life

The service life of the motor is based on the rated life of its bearings. The bearings load curve gives the radial load value, which the motors endures for 10 million rotations with 90 % reliability.

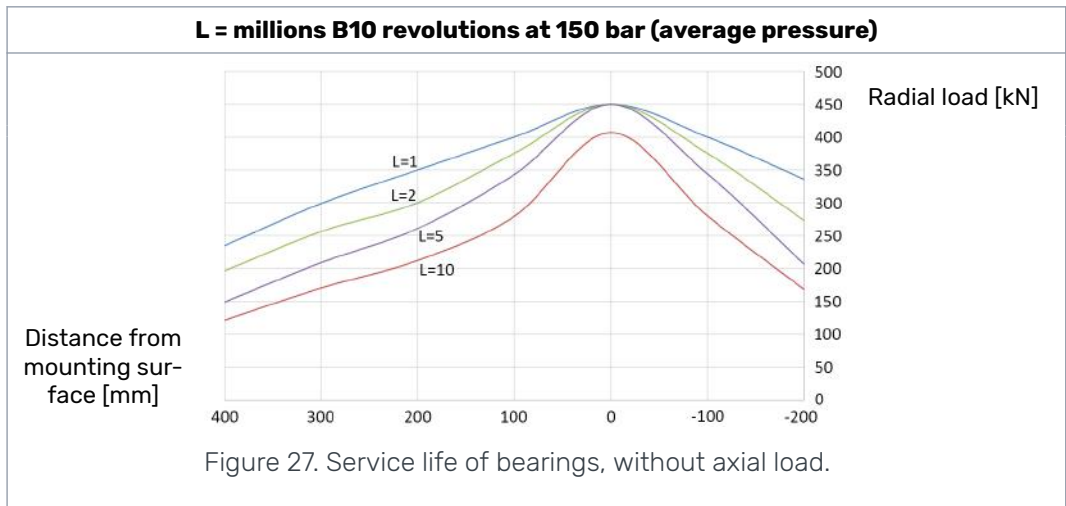



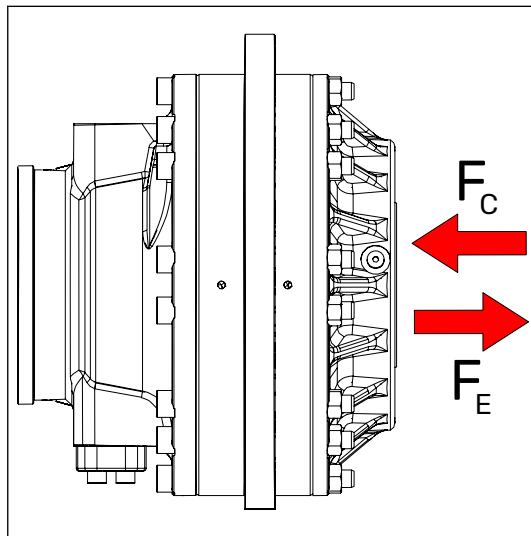

**Max. axial load, without radial load (work pressure 0 bar)**

Compression ( $F_C$ )	210 kN
Expansion ( $F_E$ )	450 kN

The service life of the bearings and maximum axial load is influenced by the work pressure. For an accurate calculations, consult your Black Bruin application engineer.

## 6 Installation Instructions

### 6.1 Mounting the motor

The installation dimensions and tightening torques are given in the product datasheet.

Check the following things before installing the motor:

- The counter surfaces must be clean and even.
- Make sure that the strength class (grade) of the fastening screws is sufficient.
- Make sure that the fastening screws are of suitable size and length.
- The fastening screws should be cleaned and oiled lightly before installing them.
- Use threadlocker only if necessary, removing the old threadlocker may be difficult.
- Remove any old threadlocker before mounting the motor.



**Note:**

When replacing fastening screws with new ones, renew all of the screws.

### 6.2 Flushing the hydraulic system

Prior to connecting the motor as part of the hydraulic system, the hydraulic circuit of the motor must always be flushed by circulating hydraulic fluid through a filter installed in place of the motor.

The flushing is carried out by circulating hydraulic fluid through the entire system with a minimum pressure for at least an hour.

- After flushing, renew all filters.



**Note:**

Flushing the hydraulic system should also be performed after every system modification or repair.

### 6.3 Commissioning procedure

Ensure that the following things are in order before starting a new or replaced motor:

- The hydraulic circuit of the motor is flushed.
- Motor is installed appropriately.
- Fill the motor case with hydraulic fluid via a filter into topmost C1 port. Make sure that topmost C2 port is connected to the drain line during the filling process to avoid the excessive pressure in the case.
- The reservoir of the hydraulic system is full.

During the initial stages of use, also take the following things into consideration:

- Do not run the motor immediately with full power. Increase the load and speed of rotation gradually.
- Observe the motor and the hydraulic system for external leaks or abnormal noises during the commissioning procedure.
- Start the motor break-in.



**Note:**

During all installation and service procedures, plug any open ports and hoses.

When filling the reservoir, add hydraulic fluid through a filter.



**Attention:**

Stressing an unused motor with full power may cause premature wear or failure of the motor.

## 7 Operating Instructions

### 7.1 Break-in period

The motor achieves its final properties during the first hours of use. Therefore all new and reconditioned motors should go through an initial break-in period.

Things to be considered during break-in period:

- The break-in period should last for at least first eight hours (8 h) of use.
- The power output should remain under 50 % of the maximum power capacity of the motor.
- The power output is limited by limiting the working pressure, the speed of rotation or both.
- The working pressure should be limited so, that pressure peaks which last over two seconds (2 s) remain under 75 % of the permissible values.



**Note:**

During the break-in period, the moving parts of the motor wear against each other so, that the wear of the parts sets to a stable state for the entire service life of the motor.

### 7.2 Use

Things to be considered during use of motors:

- Check the screw connections tightening torque and hydraulic connections regularly.
- Do not use pressure cleaning directly between the shaft and housing of the motor (the shaft seal area).
- Avoid situations in which the motors are completely submerged in water or mud.

### 7.3 Operating temperature

The operating temperature means the internal temperature of the motor. Take into considerations the following requirements for the operating temperature:

- For improved service life, avoid over 70 °C (158 °F) operating temperature.
- The highest permissible intermittent operating temperature is 85 °C (185 °F).
- The lowest permissible operating temperature is -35 °C (-31 °F).
- The temperature difference between the motor and the hydraulic fluid should be under 60 °C (140 °F).

The operating temperature may be measured from the hydraulic fluid returning from the motor. Take into account the temperature of hydraulic fluid returning from the drain line and from the return line (A or B).

### 7.4 Demounting the motor

Take into consideration the following things when demounting the motor for service or replacement:

- Release the pressure in the hydraulic lines and let the motor cool down.
- Disconnect all the hydraulic lines from the motor and plug all openings and hoses.
- Demount the motor and lift it away from its position.

- Clean the outside of the motor thoroughly, but do not use any solvents.
- Protect the cleaned motor from corrosion.
- If possible, drain all the hydraulic fluid from the motor.



**Note:**

Dispose of hydraulic fluid should be done appropriately.

## 8 Special Instructions

### 8.1 Storing the motor

During short term storage of the motor, the following should be taken into consideration:

- Cover any pressure openings and open threaded holes with suitable caps.
- Protect the unpainted surfaces from dirt and moisture.
- Store the motor in a dry place with relatively stable temperature.
- The motor should not be stored in a same place as substances with aggressive corrosive nature (solvents, acids, alkalis and salts).
- The motor should not be exposed to strong magnetic fields.
- The motor should not be exposed to strong vibration.



**Note:**

For long-term storage (over 9 months) the following additional actions are recommended:

- Damages to surface paint must be repaired.
- Protect the unpainted surfaces with suitable anti-corrosion treatment.
- Fill the motor completely with hydraulic fluid.

If these instructions are followed, the motor may be stored for approximately two years. However, as storage conditions do have a significant effect, these times should only be considered as guide values.



# No POWER like it.



## **Black Bruin Inc.**

+358 50 419 3484  
P.O. Box 633, FI-40101 JYVÄSKYLÄ, FINLAND  
[www.blackbruin.com](http://www.blackbruin.com)  
[info@blackbruin.com](mailto:info@blackbruin.com)

All the information contained in this publication is based on the latest information available at the time of publication. Black Bruin Inc. reserves the right to make changes without prior notice.